

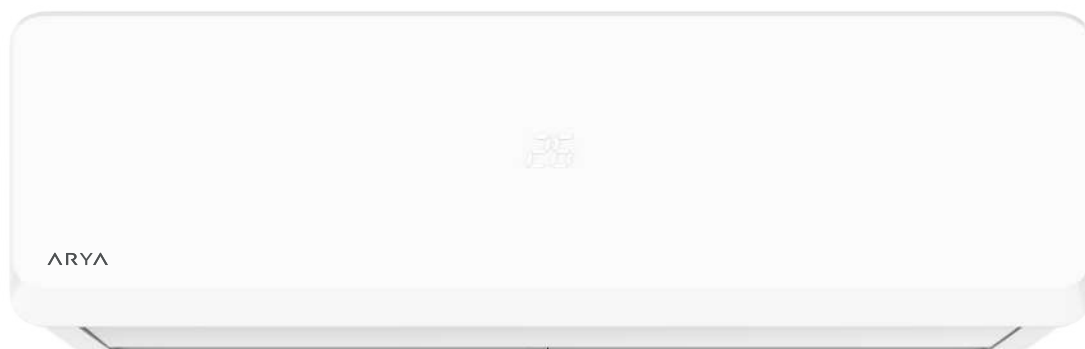

## VENTOTENE INVERTER SERIES MONOSPLIT

# MANUALE UTENTE

USER MANUAL | MANUAL DE USUARIO | BENUTZERHANDBUCH



### IMPORTANTE:

Leggere attentamente questo manuale prima dell'installazione o prima di azionare la macchina. Si prega di conservare il manuale per consultazioni future.

Si prega di controllare i modelli applicabili, tecnici dati, F-GAS (se presente) e informazioni sul produttore dal "Manuale di istruzioni - Scheda prodotto" nell'imballo dell'unità esterna.

(Solo prodotti dell'Unione Europea)

# CONTENUTI

## 1. ISTRUZIONI PER LA SICUREZZA

Descrizione dei simboli .....	1
Note di sicurezza .....	1
Istruzioni di funzionamento .....	2
Istruzioni di sicurezza .....	3

## 2. INTRODUZIONE AL PRODOTTO

Funzioni di protezione .....	4
------------------------------	---

## 3. DESCRIZIONE DEI COMPONENTI

Vista dell'unità .....	5
Schermo del display .....	6
Indicatori luminosi .....	7
Telecomando .....	8
Display del telecomando .....	9

## 4. MODALITÀ DI FUNZIONAMENTO

AUTO, HEAT, COOL, SWEEP e DRY .....	10
Funzioni di emergenza .....	11
Regolazione flusso d'aria .....	11
Funzione Sleep risparmio energetico .....	12

## 5. MANUTENZIONE

Pulizia pannello frontale e il telecomando .....	12
Pulizia del filtro .....	13
Manutenzione di inutilizzo per lungo tempo .....	14
Risparmio energetico .....	15

## 6. RISOLUZIONE DEI PROBLEMI

Analisi guasto condizionatore .....	16
Errori telecomando .....	16
Codici di errore .....	14
Risparmio energetico .....	17

## 7. NORMALE FUNZIONAMENTO

Funzionamento normale .....	18
-----------------------------	----

# 1. ISTRUZIONI PER LA SICUREZZA

## • Descrizione dei simboli



**Avvertimento:** Danni alle persone



**Attenzione:** Danni ai materiali

## • Note di sicurezza



**Avvertenza**



**Non montare da solo**

Il condizionatore d'aria funzionerà per un periodo lungo se è installato correttamente. L'installazione impropria può causare problemi quali perdita di acqua o del refrigerante, scossa elettrica o incendio.



**Attenzione**

**Si prega di confermare quanto segue prima dell'installazione**



**Specifiche di alimentazione**

Assicurarsi che la capacità della presa dell'interruttore e del cavo di alimentazione è sufficiente, la tensione è corretta e che la presa o l'interruttore siano collegati a terra. In caso contrario potrebbero esserci rischi di incendio o di scosse elettriche.



**L'ambiente di installazione**

Non installare il condizionatore d'aria in luoghi in cui siano presenti liquidi infiammabili corrosivi.



**Corretto collegamento di fili e tubature**

Un collegamento improprio può far diminuire l'efficienza o causare l'arresto del condizionatore. Potrebbero verificarsi perdite del refrigerante o dell'acqua.



**Istruzione di funzionamento**

Si prega di utilizzare il condizionatore d'aria secondo questo manuale.

## • Istruzioni di funzionamento

Bisogna usare la tensione 220V - 50Hz monofase

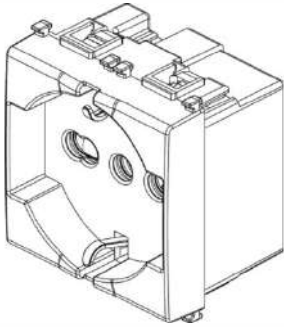

Utilizzare il cavo di alimentazione specificato; non cambiarlo.

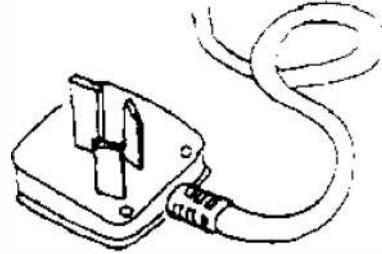

Non inserire dita o bastoncini nell'ingresso e uscita del condizionatore d'aria; la ventola in funzione può causare lesioni.

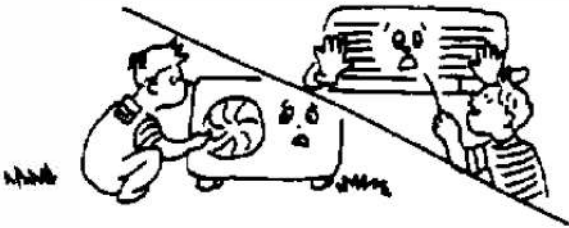

Non appoggiare nulla sull'unità esterna.



Non accendere o spegnere l'unità collegando o staccando la spina o accendendo o spegnendo l'interruttore.



Mantieni la ventilazione interna, soprattutto quando vi sono apparecchiature a gas funzionanti.



Non sostituire il fusibile con filo o altro materiale.



Staccare la spina di alimentazione o spegnere l'interruttore se il condizionatore d'aria non viene utilizzato per un lungo periodo.

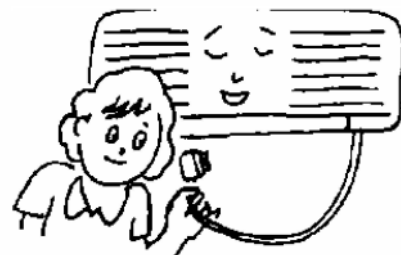

• Istruzioni di sicurezza



**Avvertenza**

L'apparecchio non è destinato all'uso da parte di bambini piccoli o disabili senza supervisione. I bambini piccoli devono essere sorvegliati per assicurarsi che non giochino con l'apparecchio. Se il cavo di alimentazione è danneggiato, deve essere sostituito dal produttore o dal servizio tecnico oppure da una persona altrettanto qualificata al fine di evitare rischi.

Non collegare la linea di terra al tubo del gas, tubo dell'acqua. Una messa a terra non corretta può causare elettro-shock.

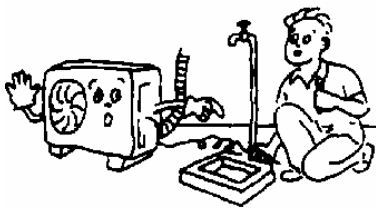

Non staccare la spina di alimentazione o spegnere l'interruttore quando è in funzione.

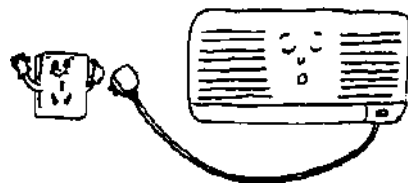

Spegnere l'unità; interrompere la fonte di alimentazione e contattare il servizio assistenza se si verificano fenomeni anomali (ad es. odore di bruciato).



Non installare il condizionatore d'aria nel punto in cui potrebbero fuoriuscire gas o sostanze infiammabili.

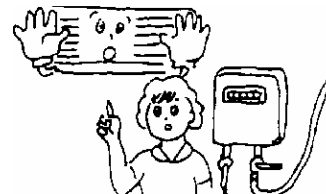

Non posizionare piante o animali direttamente nel percorso del flusso d'aria del condizionatore d'aria. Così facendo potrebbe far loro del male.



Si prega di contattare il servizio assistenza autorizzato per l'assistenza. Un servizio improprio può causare incidenti.

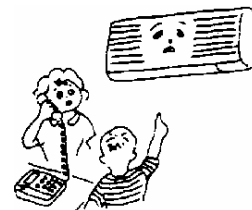

Spegnere l'unità, interrompere l'alimentazione e assicurarsi che la ventola si fermi prima di pulire l'unità.

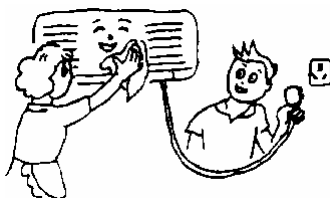

Per la rimozione e l'installazione del condizionatore, si prega di fare riferimento ai professionisti o contattare il servizio assistenza.

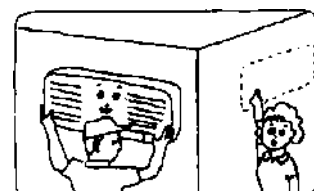

## 2. INTRODUZIONE DEL PRODOTTO

### • Funzioni di protezione

Le funzioni di protezione possono prolungare la durata del condizionatore d'aria e fornire un flusso d'aria più confortevole.

> **Protezione di avvio ritardato per il compressore**

Il compressore inizierà a funzionare almeno 3 minuti (5 minuti in modalità riscaldamento) dopo lo spegnimento per mantenere l'equilibrio di pressione del sistema di raffreddamento.

> **Osservazioni**

Ci vorrà 1 minuto affinché il compressore funzioni dopo che l'unità è stata elettrificata per la prima volta.

> **Sbrinamento**

Lo scambiatore di calore esterno può congelare se la temperatura esterna è bassa e l'umidità è alta.

In questo caso, lo sbrinamento automatico funzionerà per 3 - 10 minuti. L'indicatore di pausa sarà acceso, e sia il ventilatore interno che quello esterno non saranno in funzione.

> **Protezione di sovraccarico del HEAT** (non disponibile per il raffreddamento - soltanto del tipo di aria condizionata)

Quando la temperatura della tubazione interna è troppo elevata, il condizionatore d'aria entra nella modalità protezione da sovraccarico di riscaldamento e la velocità della ventola interna deve essere regolata automaticamente su una marcia più alta. Il ventilatore e il compressore esterni possono essere arrestati. Quando la temperatura della tubazione interna scende a un valore nominale, il condizionatore d'aria uscirà dalla modalità protezione da sovraccarico. Il motore del ventilatore interno torna allo stato normale.

> **Funzione di calore residuo** (non disponibile per il raffreddamento - soltanto del tipo di aria condizionata)

La ventola interna continuerà a funzionare a bassa velocità per 80 secondi quando il condizionatore d'aria viene arrestato in modalità riscaldamento.

> **Prova di raffreddamento del flusso d'aria** (non disponibile per il raffreddamento - soltanto del tipo di aria condizionata)

Nei primi minuti di funzionamento del riscaldamento, l'indicatore PAUSE si illumina; la ventola interna non funziona e le alette non possono essere controllate. Circa 5 minuti dopo, il condizionatore d'aria soffierà il flusso d'aria di calore, l'indicatore PAUSE è spento.

> **Evitare il gelo**

Per evitare il congelamento dello scambiatore di calore interno durante l'operazione di raffreddamento e deumidificazione, il compressore o la ventola esterna potrebbero smettere di funzionare; la velocità della ventola interna verrà regolata automaticamente su una marcia più alta.

> **Riavviamento automatico** (facoltativo)

L'unità memorizza la modalità di funzionamento, l'impostazione del flusso d'aria, l'impostazione della temperatura ecc., in modo che, in caso di interruzione dell'alimentazione quando l'unità è in funzione, restituirà automaticamente le stesse condizioni operative al ripristino dell'alimentazione.

> **Antigoccia**

Nelle operazioni di raffreddamento e deumidificazione, le alette delle feritoie possono cambiare automaticamente la posizione per evitare il gocciolamento.

### 3. DESCRIZIONE DEI COMPONENTI

- Vista dell'unità

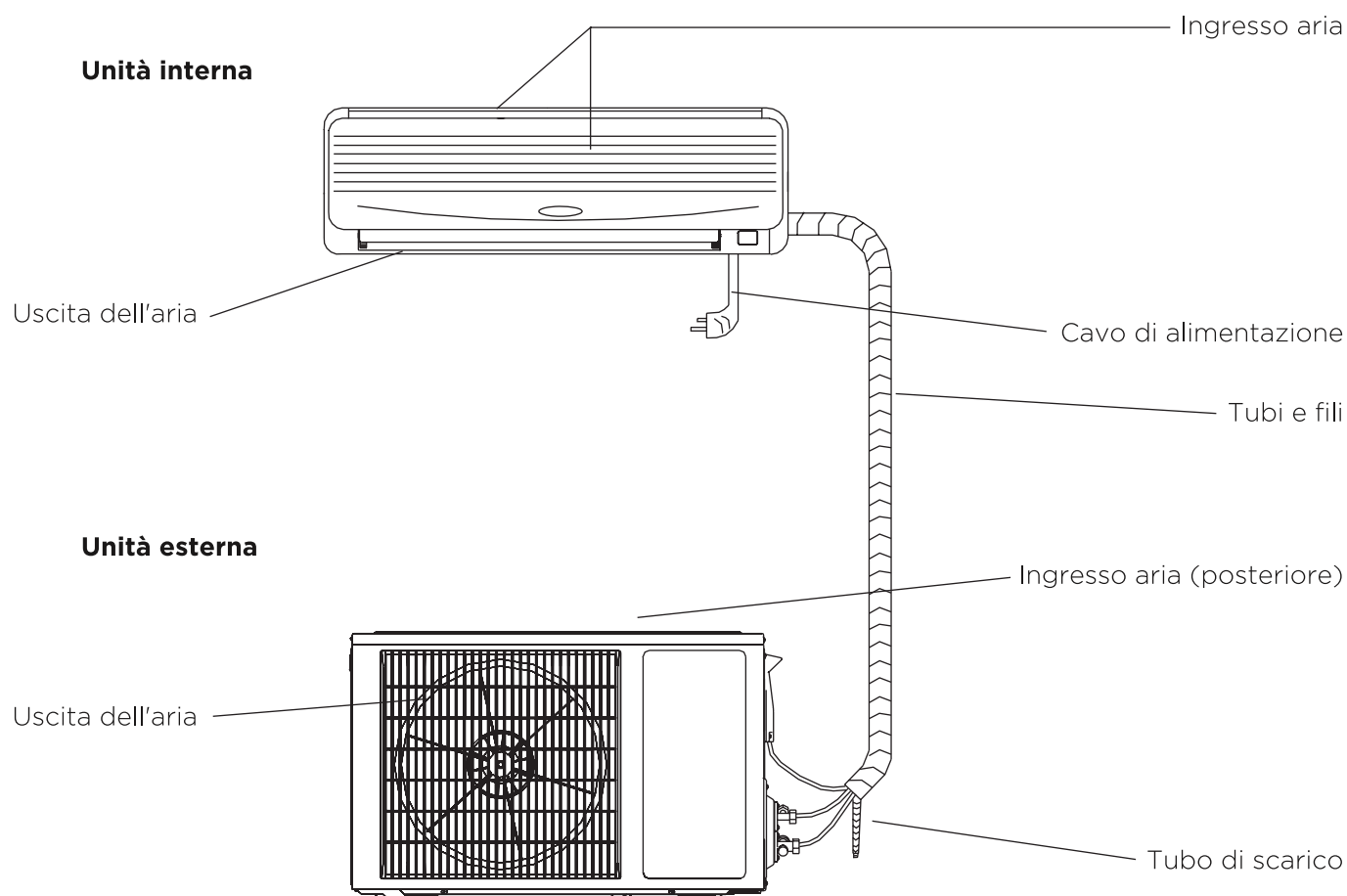

**Note**

Il condizionatore d'aria è composto da unità interna, unità esterna e telecomando. Il design e la forma sono diversi per diversi modelli. Il disegno di cui sopra è solo schematico e potrebbe essere leggermente diverso dall'apparecchio reale.

## • Schermo del display



### > Indicatore "RUN"

Questa spia luminosa è accesa quando l'unità sta funzionando. L'indicatore lampeggia quando l'apparecchio sta eseguendo lo scongelamento o il test di flusso d'aria fredda.



### > Indicatore "TIMER"

Questa spia luminosa è accesa quando sull'unità è stato impostato il Timer.



### > Indicatore "COMPRESSOR"

Questa spia luminosa è accesa quando il compressore è in funzione (opzionale).



### > Indicatore "TEMPERATURA"

indica sul display la temperatura impostata.

Quando sul display appaiono i codici di errore F4, F1 o F2, significa che il condizionatore d'aria funziona in modo anomalo.

**(Il display a LED mostrato sopra è solo di riferimento, ogni prodotto possiede un display specifico per il suo modello).**

## • Osservazioni

1. Il lampeggiamento di qualsiasi indicatore indica che il condizionatore d'aria funziona in modo anomalo, si prega perciò di contattare tempestivamente il servizio tecnico.
2. **Funzione a:** il condizionatore d'aria visualizzerà solo l'indicatore "RUN" per risparmiare energia elettrica se non riceve alcun segnale dal telecomando dopo 30 secondi. Se invece riceve per la seconda volta il segnale dal telecomando, il display continua a visualizzare gli indicatori corrispondenti.

**Funzione b:** gli indicatori sul display possono ancora essere azionati dal tasto "Display" del telecomando.

**NOTA: la funzione a o la funzione b sono opzionali e vengono aggiunte al dispositivo prima della sua uscita dalla fabbrica.**

3. Fare riferimento alle seguenti pagine se esistono differenze con la descrizione sopra menzionata del vostro condizionatore d'aria.



## • Indicatori luminosi

### ① Indicatore “PAUSE”

Questo indicatore si illumina di rosso quando il condizionatore d'aria è in modalità sbrinamento o raffreddamento a prova di flusso d'aria.

### ② Indicatore “RUN”

Questo indicatore si illumina di verde quando l'unità si trova nella modalità “RUN”;

### ③ Indicatore “TIMER”

Questo indicatore si illumina di giallo quando l'unità è in modalità TIMER.

### ④ Indicatore “AIR REFRESH” (opzionale)

Questo indicatore si illumina di verde quando l'unità è in modalità Air Refresh e non si accenderà se l'unità non ha la funzione Air Refresh.

### ⑤ Indicatore “RECEIVER”

Ricezione del segnale del telecomando.

**Note:** Se uno degli indicatori “RUNNING”, “PAUSE” o “TIMER” lampeggia, contattare immediatamente il servizio tecnico.

TELECOMANDO

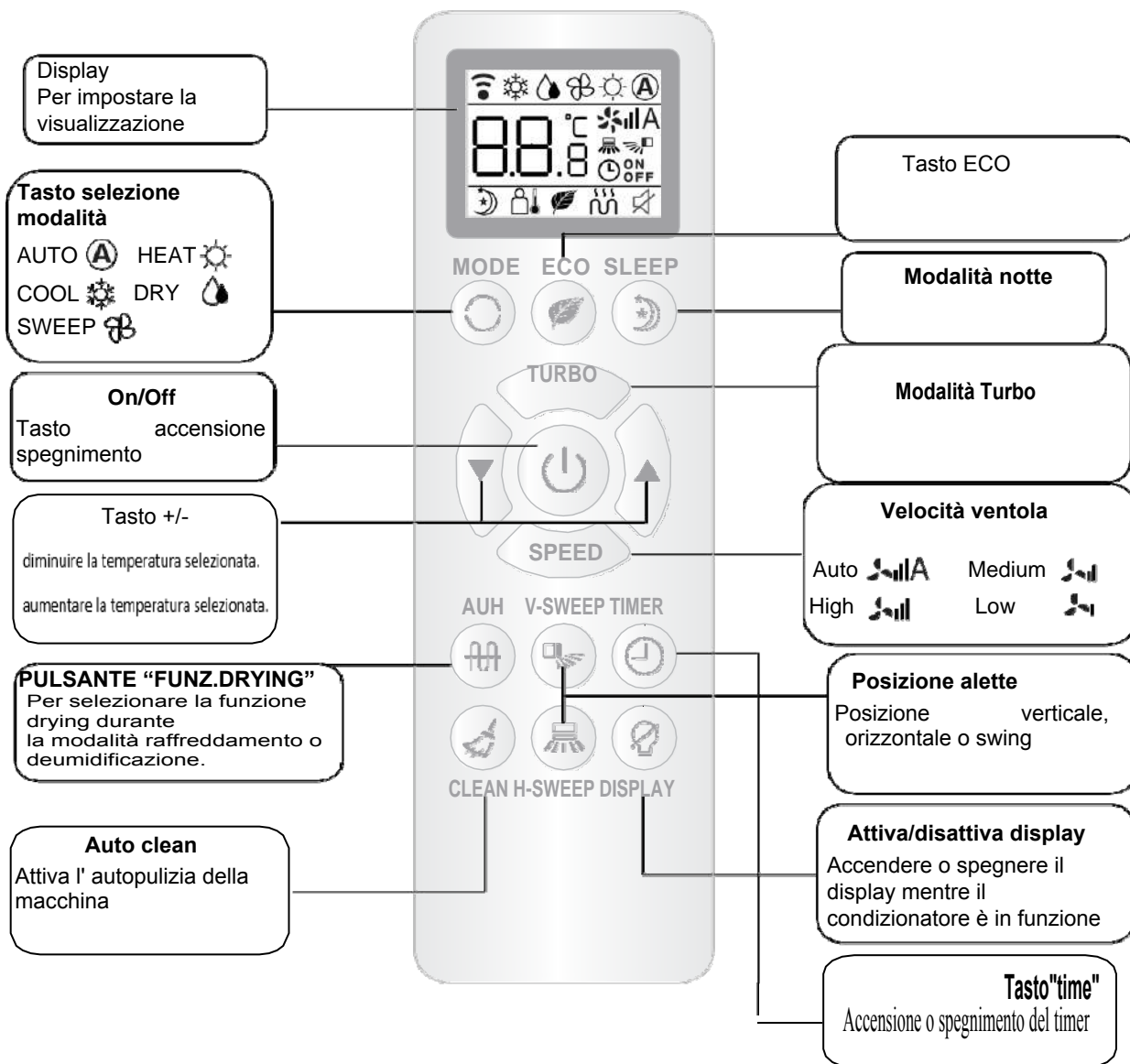

**CONSIGLI :**

Se l'utente desidera raffreddare o riscaldare rapidamente l'aria della stanza, può premere il pulsante "turbo" in modalità raffreddamento o riscaldamento, il condizionatore funzionerà in funzione di alimentazione. Se si preme nuovamente il pulsante "turbo", il condizionatore d'aria uscirà dalla funzione di alimentazione.

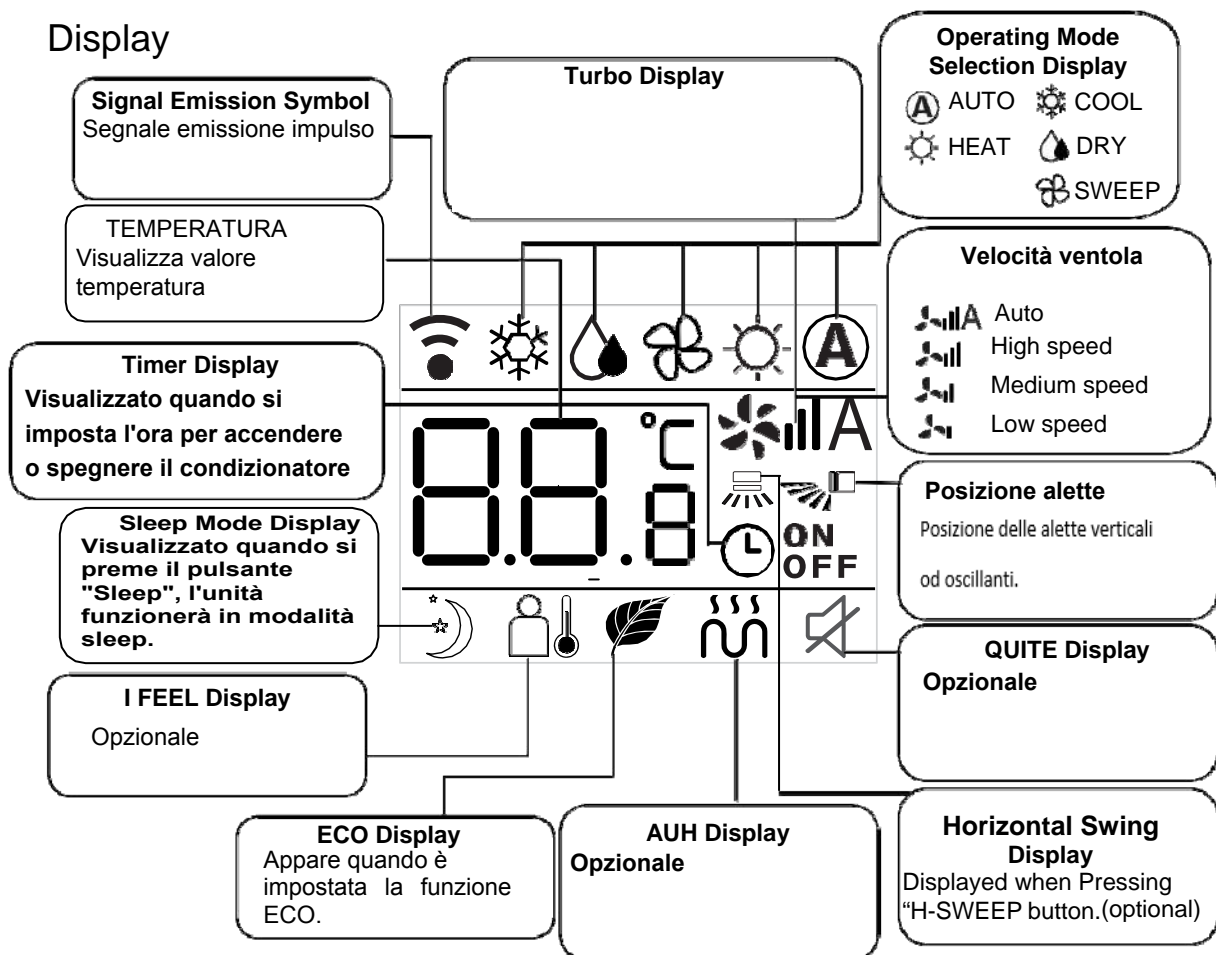

**Istruzioni telecomando:**

- Il telecomando utilizza due batterie alcaline AAA in condizioni normali, le batterie durano circa 6 mesi. Si prega di utilizzare due nuove batterie di tipo simile (prestare attenzione ai poli durante l'installazione).
- Quando si utilizza il telecomando, puntare l'emettitore del segnale verso il ricevitore dell'unità interna; Non dovrebbero esserci ostacoli tra il telecomando e l'unità interna  
La pressione simultanea di due pulsanti risulterà in un'operazione errata  
Non utilizzare apparecchiature wireless (come telefoni cellulari) vicino all'unità interna. Se si verificano interferenze a causa di ciò, spegnere l'unità, scollegare la spina di alimentazione, quindi ricollegarla e accenderla dopo un po'.
- Non mettere il telecomando sotto la luce del sole o vicino fonti di calore

Le batterie devono essere rimosse dall'apparecchio prima che venga rottamato e che siano smaltite in sicurezza.

• **Funzioni di emergenza**

Se non si riesce a trovare il telecomando o le batterie del telecomando sono scariche, usare l'interruttore di emergenza.

• **Regolazione flusso d'aria**

Per avviare la funzione del flusso d'aria

**Modo di manovra**

1. Quando il condizionatore d'aria è spento.
  - Quando il condizionatore dell'aria e' spento, premere il pulsante "AIR REFRESH", il condizionatore d'aria si accenderà, premendo il pulsante il SWEEP si attiverà la funzione " HEALTH "
  - Ripremendo il pulsante " HEALTH " si annulla la funzione.
  - Ripremendo di nuovo il pulsante " HEALTH " il condizionatore d'aria si spegnerà.
  - Quando il condizionatore dell'aria funziona con la modalità " HEALTH ", se si preme il pulsante "ON/OFF" si può cambiare la modalità (COOL, HEAT etc.) preservando la funzione " HEALTH "
2. Il condizionatore d'aria è acceso.
 

Quando l'aria condizionata e' nello stato acceso premere il bottone di " HEALTH " avvia la funzione dell'aria fresca.

• **Regolazione flusso d'aria**

**Regolazione flusso d'aria orizzontale**

Usare le mani per regolare la griglia dell'aria per regolare il flusso a destra o a sinistra. (Quadro 5.6.1)

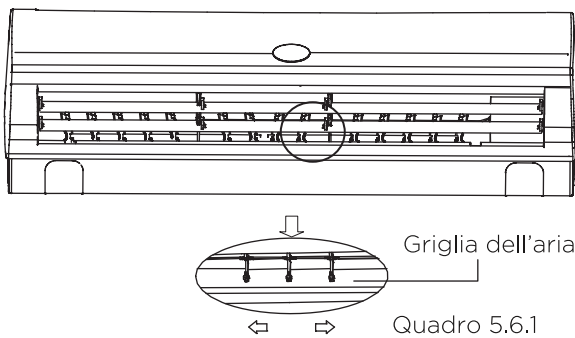

**Attenzione:**  
All'interno c'è il ventilatore, non inserire le mani!

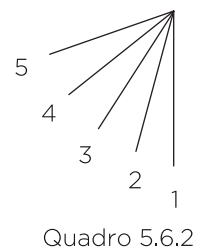

**Regolazione flusso d'aria verticale**

Premere ripetutamente il pulsante "SWEEP" sul telecomando, le alette possono essere regolate nella posizione fissa 1-5 (Quadro 5.6.2) l'oscillazione automatica si attiva in diverse modalità, le alette oscillano ripetutamente nell'intervallo impostato.

## • Funzione SLEEP risparmio energetico

1. Quando il condizionatore d'aria è acceso, premere il tasto "SLEEP" per accedere alla modalità "SLEEP" sul telecomando apparirà questo simbolo ☾
2. Premendo di nuovo il tasto ☾ "SLEEP", scomparirà sul telecomando è la funzione di sospensione (risparmio energetico) verrà annullata.

## Note

1. Funzione a: in modalità di sospensione, la temperatura impostata verrà aumentata dopo 1 ora di funzionamento in modalità fredda e SECCA; diminuirà dopo 1 ora di funzionamento in modalità riscaldamento. La temperatura impostata sarà controllata tra 16°C e 32°C. Quando il condizionatore d'aria è in modalità SLEEP la velocità della ventola interna è impostata su livello medio, ma l'utente può modificare la velocità della ventola tramite il telecomando.
2. Funzione b: in modalità sospensione, la temperatura impostata e la velocità della ventola interna non cambieranno, ma sul display del condizionatore d'aria si spegnerà ad eccezione dell'indicatore "RUN".

## 5. MANUTENZIONE

Un'attenta manutenzione e revisione anticipata possono prolungare la durata del condizionatore d'aria e risparmiare spese di elettricità.

### Attenzione

1. Arrestare il condizionatore d'aria tramite il telecomando ed estrarre a spina prima di seguire interventi di assistenza e manutenzione.
2. Non sostare su oggetti instabili durante la pulizia o la manutenzione del condizionatore d'aria altrimenti si potrebbero causare lesioni personali.
3. Non toccare la parte metallica del corpo del condizionatore d'aria quando si rimuove il pannello anteriore, altrimenti si potrebbero causare lesioni personali.



## • Pulizia del pannello anteriore e del telecomando

Se non è possibile rimuovere lo sporco, pulirlo con un panno umido caldo (imbevuto di acqua calda inferiore a 40 !)

### Attenzione

1. Non pulire l'unità con acqua, potrebbe causare scosse elettriche.
2. Non pulire il telecomando con acqua.
3. Non pulire con alcool, benzina, olio, o lucidante.
4. Non pulire l'unità in modo violento, altrimenti il pannello anteriore potrebbe cadere.
5. Non pulire il pannello anteriore o il telecomando con spazzole di metallo; può danneggiare la superficie.



• Pulizia del filtro

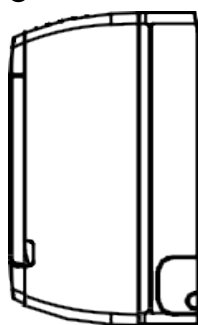

Quadro 5.2.1

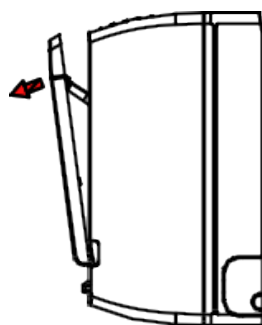

Quadro 5.2.2

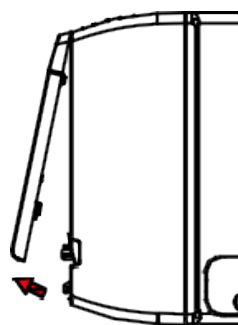

Quadro 5.2.3

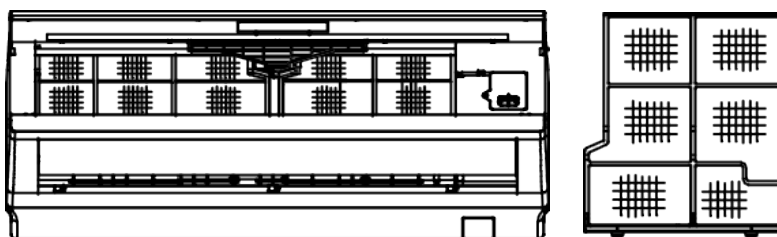

Quadro 5.2

1. Aprire il pannello frontale.
2. Sollevare la parte sporgente, quindi tirarla verso il basso, rimuovere il filtro dell'aria.
3. Pulirlo con aspirapolvere o acqua. Se il filtro dell'aria è molto sporco, pulirlo con acqua calda e sapone o detergente delicato. Quindi asciugarlo all'ombra.
4. Inserire il filtro dell'aria nella posizione precedente e chiudere il pannello anteriore.

**Attenzione:**

1. Il filtro dell'aria deve essere pulito almeno una volta ogni due settimane, altrimenti la capacità di riscaldamento o raffreddamento sarà ridotta.
2. Non pulire il filtro dell'aria con una spazzola di metallo; potrebbe essere danneggiato.

• **Manutenzione di inutilizzo per lungo tempo**

1. Far oscillare per 3-4 ore per far asciugare l'interno del condizionatore.



2. Spegnerne con il telecomando e togliere la spina dell'alimentazione

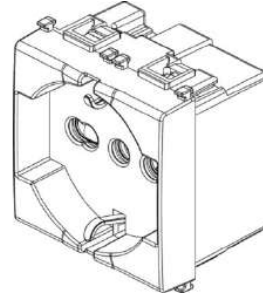

3. Fare la pulizia del filtro dell'aria



2. togliere le batterie del telecomando



• **Risparmio energetico**

**Inserire la temperatura adatta**

Non impostare la temperatura interna troppo bassa, se la stanza è troppo fredda, è dannoso per la salute.

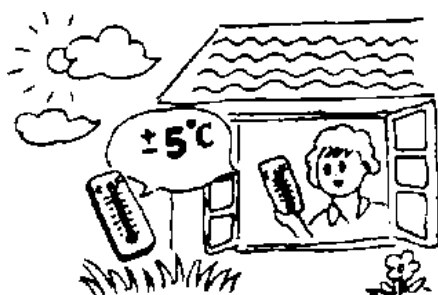

**Evitare la luce solare diretta**

Quando si sta raffreddando una stanza, utilizzare una tenda per evitare la luce solare diretta.

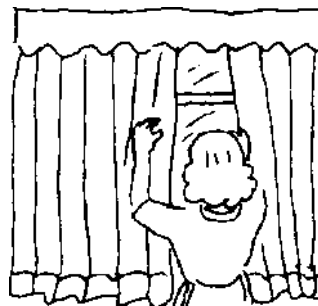

**Evitare fonti di calore dirette.**

Durante il raffreddamento di una stanza, l'utilizzo di fonti di calore può influire sulla capacità di raffreddamento.

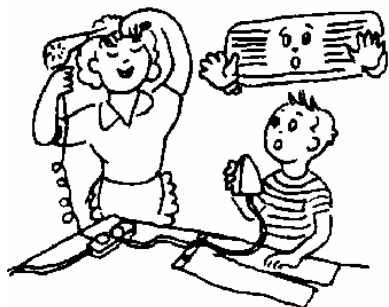

**Chiudere bene porte e finestre.**

L'aria esterna in ingresso influirà l'efficienza di raffreddamento o di riscaldamento.



**Pulizia del filtro dell'aria**

Mantenere il filtro dell'aria sempre pulito garantisce un'alta efficienza del funzionamento dell'aria condizionata.

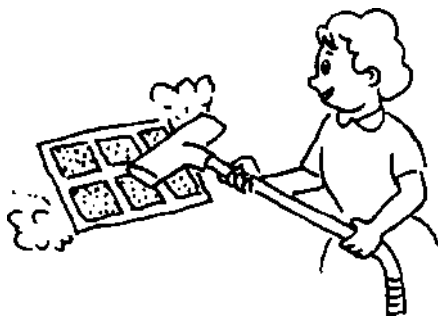

**Buona ventilazione**

Non mettere nessun oggetto davanti all'ingresso e all'uscita dell'unità esterna.

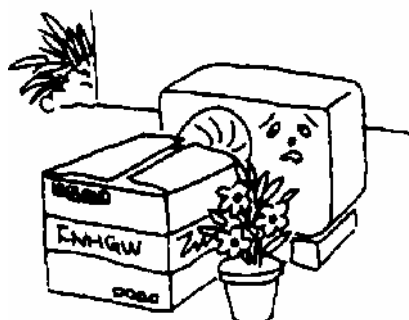



## 6. ANALISI GUASTO CONDIZIONATORE

### • Il condizionatore è in errore

#### Verifica prima della riparazione

Tipo di guasto	Verifiche da effettuare
Aria condizionata non funziona	1. Controllare se l'alimentazione è disconnessa.
	2. Controllare se l'interruttore è acceso o il fusibile è bruciato.
	3. Controllare le batterie del telecomando.
	4. Controllare se il tempo di funzionamento inserito è stato raggiunto.
	5. Controllare se apparecchiature radio sono in funzione entro 1 metro.
Scarse prestazioni di raffreddamento o riscaldamento	1. Controllare se l'ingresso delle prese d'aria sono ostruite.
	2. Controllare se la polvere ostruisce il filtro.
	3. Ci possono essere troppe persone all'interno della stanza.
	4. Controllare che porte e finestre siano chiuse.
	5. Controllare se la velocità del ventilatore o la temperatura impostata non sono corrette..

### • Il telecomando è in errore

#### i fenomeni normali del guasto

Fenomeno del guasto	Motivo del guasto
Non è possibile controllare gli arresti del ventilatore o la velocità del ventilatore	1. Quando il condizionatore d'aria è in modalità DEUMIDIFICAZIONE o SONNO, la velocità della ventola non può essere controllata.
	2. Quando il condizionatore d'aria è in COOL AIRFLOW PROOF o DEFROSTING funzionamento (in modalità HEAT), il motore del ventilatore si arresterà.
	3. Quando il condizionatore d'aria è in modalità RAFFREDDAMENTO o DEUMIDIFICAZIONE, se il condizionatore d'aria entra in modalità antigelo, quindi la velocità della ventola non può essere controllata.
	4. Quando il condizionatore dell'aria è nella modalità RAFFREDDAMENTO o DRY, se il condizionatore dell'aria entra nel funzionamento di congelprevenzione, allora la velocità non può essere controllata.
	5. Quando il condizionatore d'aria è in modalità RISCALDAMENTO, se il condizionatore d'aria entra in funzione di prevenzione del sovraccarico di riscaldamento, la velocità della ventola non può essere controllata.

**• Codici di errore**

1. Errore EEPROM su PCB unità interna---EE
2. Guasto del motore PG ---FO
3. Guasto sensore della temperatura della serpentina dell'unità interna---F3
5. Rilevamento dell'anomalia di zero crossing del motore PG-E1
6. Anomalia del sistema esterno-E8
7. Errore EEPROM su PCB unità esterna---EF
8. Le comunicazioni interne non possono essere accettate---F6
9. Guasto di comunicazione tra unità esterna e IPDU--- F8
10. Guasto del compressore --E4/E3
11. Malfunzionamento del modulo IPM---F9
12. Guasto del sensore della temperatura del tubo di scarico---F5
13. Guasto del sensore della temperatura di induzione-- -E5
14. Guasto sensore della temperatura della serpentina dell'unità interna---F4
15. Guasto del sensore di temperatura esterna--- F2
16. Avaria motore a corrente continua esterno--- E2

# SAFETY PRECAUTIONS



**WARNING: Following these basic precautions will reduce the risk of fire, electrical shock, injury or death when using your air conditioner.**

1. Air conditioner must be connected to proper electrical outlet or breaker with the correct electrical supply. And only the specified power can be used.
2. Proper grounding must be ensured to reduce the risk of shock and fire  
**DO NOT CUT OR REMOVE THE GROUNDING PRONG.** If you do not have a three-prong electric receptacle outlet or breaker in the wall, have a certified electrician install the proper receptacle or breaker. The wall receptacle or breaker **MUST** be properly grounded.
3. **DO NOT** use if power cord is frayed or otherwise damaged. Also avoid using it if there are cracks or abrasion damage along the length, plug or connector.
4. **DO NOT** USE AN ADAPTER OR AN EXTENSION CORD.
5. **DO NOT** block airflow inside or outside the air conditioner with blinds, drapes, protective covers, shrubs or blusher.
6. Be careful of sharp edges on the front and rear fins of the unit that could cut and cause serious injury.
7. Be careful when lifting the air conditioner to install or remove the unit. Always use two or more people for this.
8. Always cut off the power of air conditioner before servicing it or moving it.
9. In some type of units, there is no appropriate plug corresponding to its power cord because of power, Under this condition, an appropriate power breaker should be linked to its power cord, therefore, the instruction part associated with plug using is not available for these types.

# CONTENTS

## 1. SAFETY INSTRUCTIONS

Symbol Description.....	2
Installation Instruction.....	2
Operating Instruction.....	3
Safety Instruction.....	6

## 2. PRODUCT INTRODUCTION

Protect Functions.....	7
------------------------	---

## 3. DESCRIPTION OF COMPONENTS

View of Unit.....	8
Display screen.....	9
Remote Controller .....	10
Remote Controller Display .....	11

## 4. SERVICE AND MAINTENANCE

Clean the Front Panel and Remote Controller.....	13
Clean Air Filter.....	13
No Use for Long Time.....	14
Recommendations for Energy Saving.....	15



## 5. TROUBLESHOOTING

Air Conditioner is in Error.....	16
Remote Controller is in Error.....	16

## 6. NORMAL PHENOMENONS.....17

# SAFETY INSTRUCTIONS

## 〔Symbol Description〕

	<b>Warning:</b>	A symbol indicating operation which may cause personnel casualties or serious damages.
	<b>Caution:</b>	A symbol indicating operation which may cause personnel casualties or property damages.

## 〔Installation Instruction〕



**Warning**



**Never install by yourself.**

Split type air conditioner will work for you for a long period of time if it is correctly installed. Improper installation could cause problems such as leakage of water or refrigerant, electric shock or fire.



**Caution**

**Please confirm the following before installation**

**Power specifications**  
 Make sure that the capacity of socket or breaker and power cable is sufficient, the voltage is correct and the socket or breaker is grounded. There may be hazard of fire or electric shock otherwise.

**Installation environments**  
 Do not install air conditioner at the place where there is flammable or corrosive air.

**Proper connection of wires and piping**  
 Improper connection may decrease the efficiency or cause air conditioner stop running. Water or refrigerant leakage may be resulted as well.

**Operating instruction**  
 Please operate air conditioner in accordance to this manual.

## 〔Operating Instruction〕

**WARNINGS**

Following the safety messages is very important. These messages can save you from being injured or killed. Warning symbols alert you to be careful and means danger. Always follow instructions to be safe and reduce chances of injury or death. Warning and danger signs will precede safety messages.

**Electrical safety**

**Grounding:** This room air conditioner must be grounded.



Grounding reduces the risk of electric shock by providing an escape wire for the electric current.

If the power cord has a grounding plug with a grounding wire, plug it into an outlet that is properly installed and grounded.

If the power cord has not a grounding plug with a grounding wire, the grounding wire must connect the breaker that is properly installed and grounded.

**Warning:** Improper use of the grounding plug or breaker can result in a risk of electric shock. Call a qualified electrician if you don't understand the grounding instructions or if you are not sure if the air conditioner is properly grounded. If the wall outlet or breaker is not grounded, please contact an electrician to have it replaced with a properly grounded outlet or breaker.

**Do not, under any circumstances, cut or remove the third (ground) prong from the power cord.**

**Adapter plug: We strongly advise against using an adapter plug or breaker.**

**Operating conditions**

1. Temperature: T1 instance:  $-7^{\circ}\text{C}\sim 43^{\circ}\text{C}$  ( $16^{\circ}\text{C}\sim 43^{\circ}\text{C}$  in cooling-only type)  
T3 instance:  $-7^{\circ}\text{C}\sim 52^{\circ}\text{C}$  ( $16^{\circ}\text{C}\sim 52^{\circ}\text{C}$  in cooling-only type)

If the unit runs beyond the temperature for a long time, it may cause cooling capacity to decrease or protector to work.

2. Relative humidity: <80%

If the unit runs beyond the humidity range, condensate may be formed near blade and outlet of air conditioner. It's normal.

3. In heating operation, strange smell may come from the unit. It is Normal phenomenon.
4. The performance parameters refer to name plate.
5. The waterproof level of indoor unit is IPX0. Do not use it in the laundry or bathroom.
6. The outdoor unit can't be installed in a closed area.
7. Fuse: T3.15AL250V, rated current: 3.15A.

## Tips

- Install the unit on the north side, as normally that is the shaded side. This will enhance the operation of your unit.
- Use correct electric voltage and proper ampere for the unit to run effectively.
- Only let a certified electrician do any modifications to your electrical outlet or breaker.
- Use a dedicated line for the operation of your air conditioner to avoid the possibility of an electrical surge.
- If the supply cord is damaged, it must be replaced by the manufacturer or its service agent or a similarly qualified person in order to avoid a hazard.
- The dimensions of the space necessary for correct installation of the appliance including the minimum permissible distances to adjacent structures.
- The appliance shall be installed in accordance with national wiring regulations.
- Disconnect the power supply before cleaning and maintenance.
- If the appliance is not connected by plug, an all-pole disconnection device which has at least 3mm separation distance in all pole and a residual current device(RCD)with the rating of above 10mA shall be incorporated in the fixed wiring according to the national rule.
- If the appliance is connected by plug, it must be positioned so that the plug is accessible.

## Energy Saving Guide

- When installing your air conditioner make sure to seal all areas where there is a possibility of air leakage.
- Airflow should not be blocked inside either by curtains, drapes or furniture or outside by shrubs or bushes.
- Do not needlessly use an electrical light or other appliances that produce heat.
- Keep the blinds and the drapes drawn on all the other window.
- While cooking use an exhaust fan in the kitchen to remove the excess heat produced.

〔Operating Instruction〕

Only single-phase a.c. power can be used.  
please refer to nameplate for details.

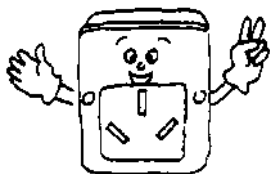

Use the specified power cord; do not  
change it.

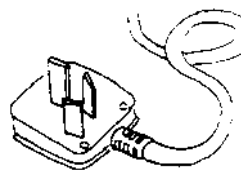

Do not put fingers or sticks into the inlet or  
outlet of air conditioner; the running fan may  
cause injuries.

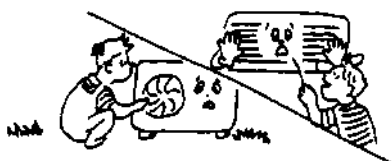

Do not put anything on the outdoor unit.



Do not switch on or off the unit by plugging or  
pulling off the plug, or by switching on or off  
the breaker .



Keep indoor ventilated, especially when  
there is operating gas equipment.



Do not substitute fuse with lead wire or other  
materials.



Pull off power plug or switch off breaker if  
the air conditioner is not used for a long  
time.

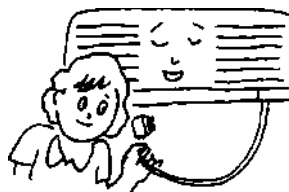





〔Safety Instruction〕

 **Warning:** The appliance is not intended for use by young children or infirm persons without supervision. Young children should be supervised to ensure that they do not play with the appliance. If the supply cord is damaged, it must be replaced by the manufacturer or its service agent or a similarly qualified person in order to avoid a hazard.

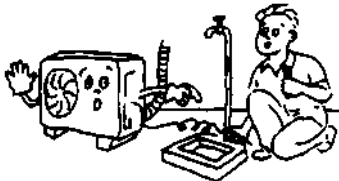
Do not connect the earth line to gas pipe, water pipe. Improper grounding may cause electric shock.



Do not pull off the power plug or switch off the breaker when it is in operation.



Switch off the unit; cut off the power source and contact service agent if there is abnormal phenomenon (e.g. burning smell comes out).



Do not install air conditioner at the place where flammable gas may leak.

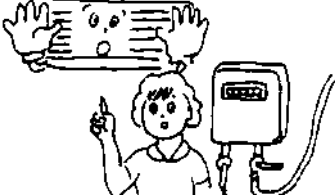

Do not place plants or animals directly in the path of the air conditioner's airflow. Doing so could harm them.



Please contact service agents for service. Improper service may cause accident.

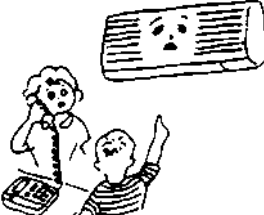

Switch off the unit, cut off the power source and make sure the fan stops before cleaning the unit.

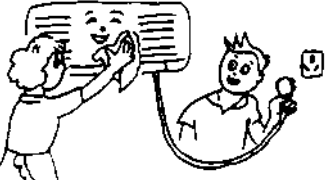

For removal and installation of air conditioner, please refer to professionals or contact service agents.



---

## PRODUCT INTRODUCTION

### 〔Protect Functions〕

Protect functions can prolong the air conditioner's service life and provide more comfortable airflow.

#### **Delay-starting protection for the compressor**

The compressor will restart working at least 3 minutes (5 minutes in heating mode) after being turned off to keep the pressure balance of the cooling system.

**Remarks:** There will be 1 minute for the compressor to work after the unit is electrified for the first time.

#### **Defrosting (not available for cooling-only type air conditioner)**

The outdoor heat exchanger may frost if the outdoor temperature is low and humidity is high. In this case, auto-defrosting has operated for 3~10 minutes. pause indicator will be on, indoor and outdoor fan stop.

#### **Heating overload protection (not available for cooling-only type air conditioner)**

When the temperature of indoor pipe is too high, air conditioner enters heating overload protection. And indoor fan speed should be adjusted to a higher gear automatically. Outdoor fan and compressor may be stopped. When indoor pipe temperature drops to a rated value, air conditioner will exit heating overload protection. Indoor fan motor resumes to the normal status.

#### **Blowing residual heat function (not available for cooling-only type air conditioner)**

Indoor fan will keep running at low fan speed for 80 seconds when air conditioner is stopped in heating mode.

#### **Cooling airflow proof (not available for cooling-only type air conditioner)**

In the first several minutes of heating operation, PAUSE indicator lights; indoor fan doesn't run and louver blades can not be controlled. About 5 minutes later, air conditioner will blow heat airflow, PAUSE indicator is off.

#### **Freeze-prevention**

To prevent indoor heat exchanger freezing in cooling and dehumidification operation, compressor or outdoor fan may stop running; indoor fan speed will be adjusted to a higher gear automatically.

#### **Dry for enzyme-prevention (optional)**

Indoor fan motor will go on running for 3 minutes at low fan speed when turned off in cooling mode in order to keep dry condition inside the unit.

#### **Reset power or Auto restart( alternative)**

Reset power: When there is a power suspension, air conditioner will automatically switch off. When the power is back, the unit will automatically reset power. For energy saving if there is no person in the room, air conditioner will stay in PAUSE status. User needs to turn on Air conditioner by remote controller.

Auto restart: The unit memories the operation mode, air flow setting, temperature setting etc., so that should there be a power failure when the unit is in operation, it will automatically return the same operating conditions when the power is restored.

#### **Cooling overload working (optional)**

In cooling operation, if the temperature of outdoor heat exchanger is too high, indoor fan speed will be adjusted to a lower gear automatically and compressor may be stopped.

**Drip proof (optional)**

In cooling and dehumidification operation, louver blades can change the position automatically to prevent from dripping.

## DESCRIPTION OF COMPONENTS

### 〔View of Unit〕

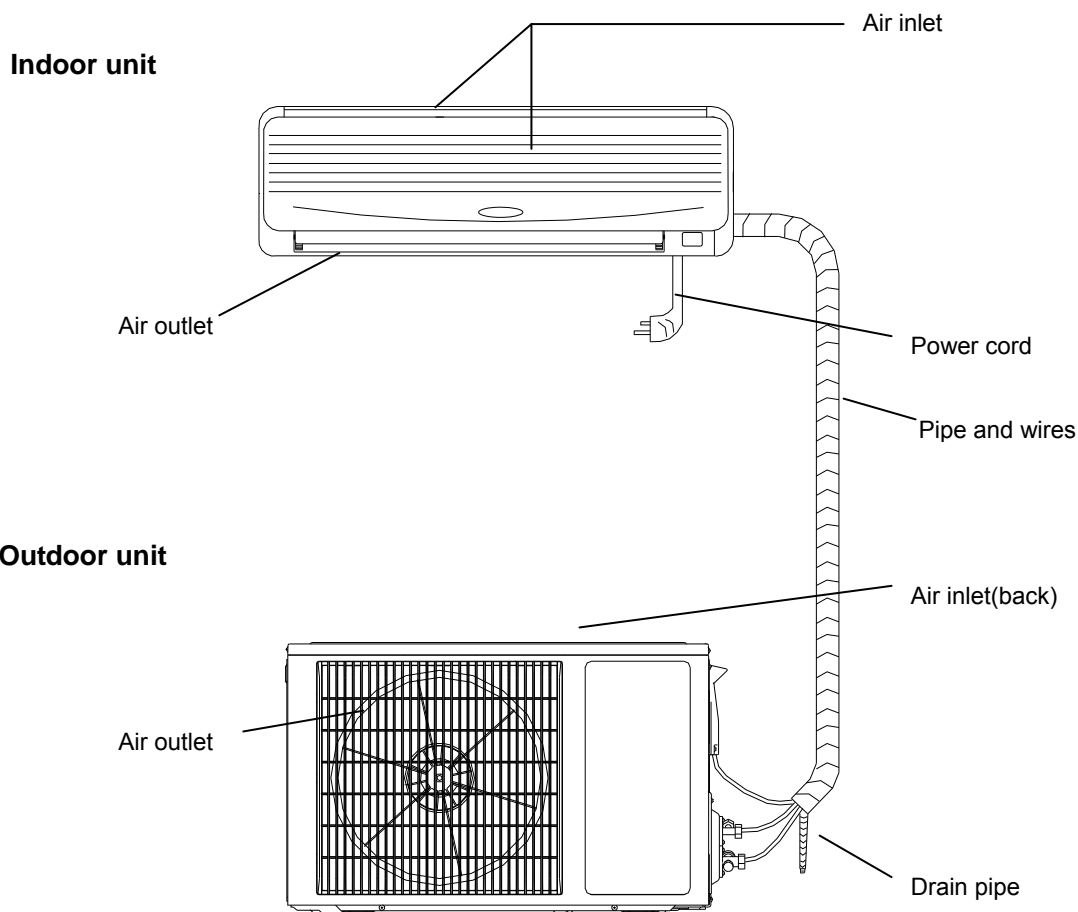

**Remarks:**

The air conditioner is consisting of indoor unit, outdoor unit and remote controller. The design and shape are different for different models. The above figures are only schematic, and they may be slightly different from the actual appliances you selected.

## 〔Display screen〕



**Health indicator:** This light is on when the UVC function or the Cold plasma generator is working.



**Timer indicator:** This signal light is on when the unit is in Timer.



**Compressor indicator:** This signal light is on when the compressor is running



**WIFI indicator:** Flashing on behalf of searching, lighting on behalf of WIFI completed connection, Which means WIFI function can be operation and application. (For more details, please refer to the WIFI instruction manual)"

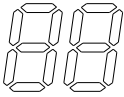

**Temperature indicator:** This display can show the set temperature .when the indicator display F4,F1orF2, means the air conditioner runs abnormally

(The above LED display is for reference only, subject to the actual product)

〔Remote Controller〕

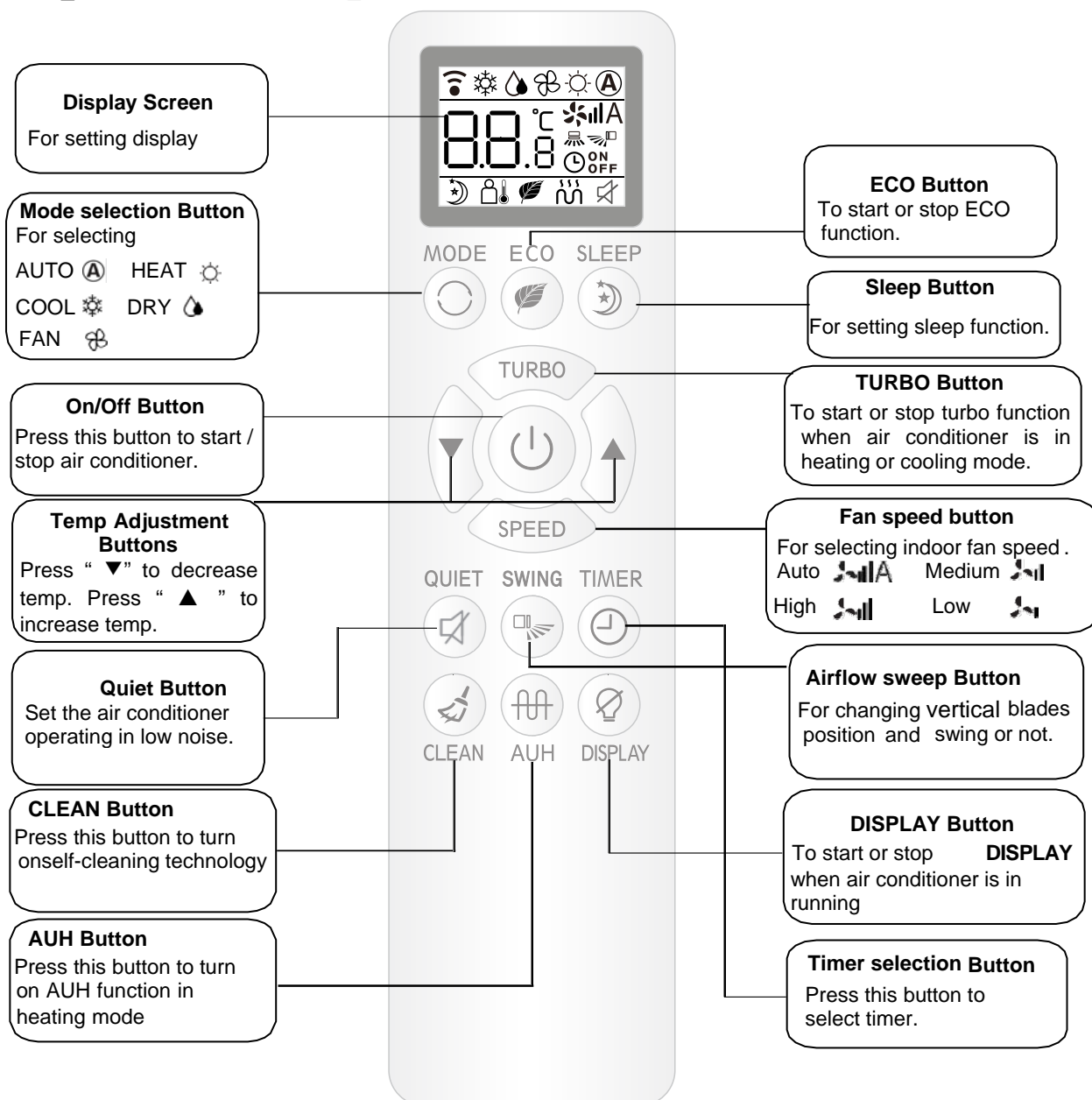

**Remarks:**

1. The function and display of Heat is not available for cooling-only air conditioner. .
- 2.HEAT、AUTO function and display are not available for cooling-only type air conditioner.
- 3.If user want to make the room air cool or warm quickly ,user can press “turbo” button incooling or heating mode,air conditioner will run in power function.If press “turbo” button again, air conditioner will exit power function.
- 4.The above illustration of remote controller is only for reference, it may be slightly different from the actual product you selected.

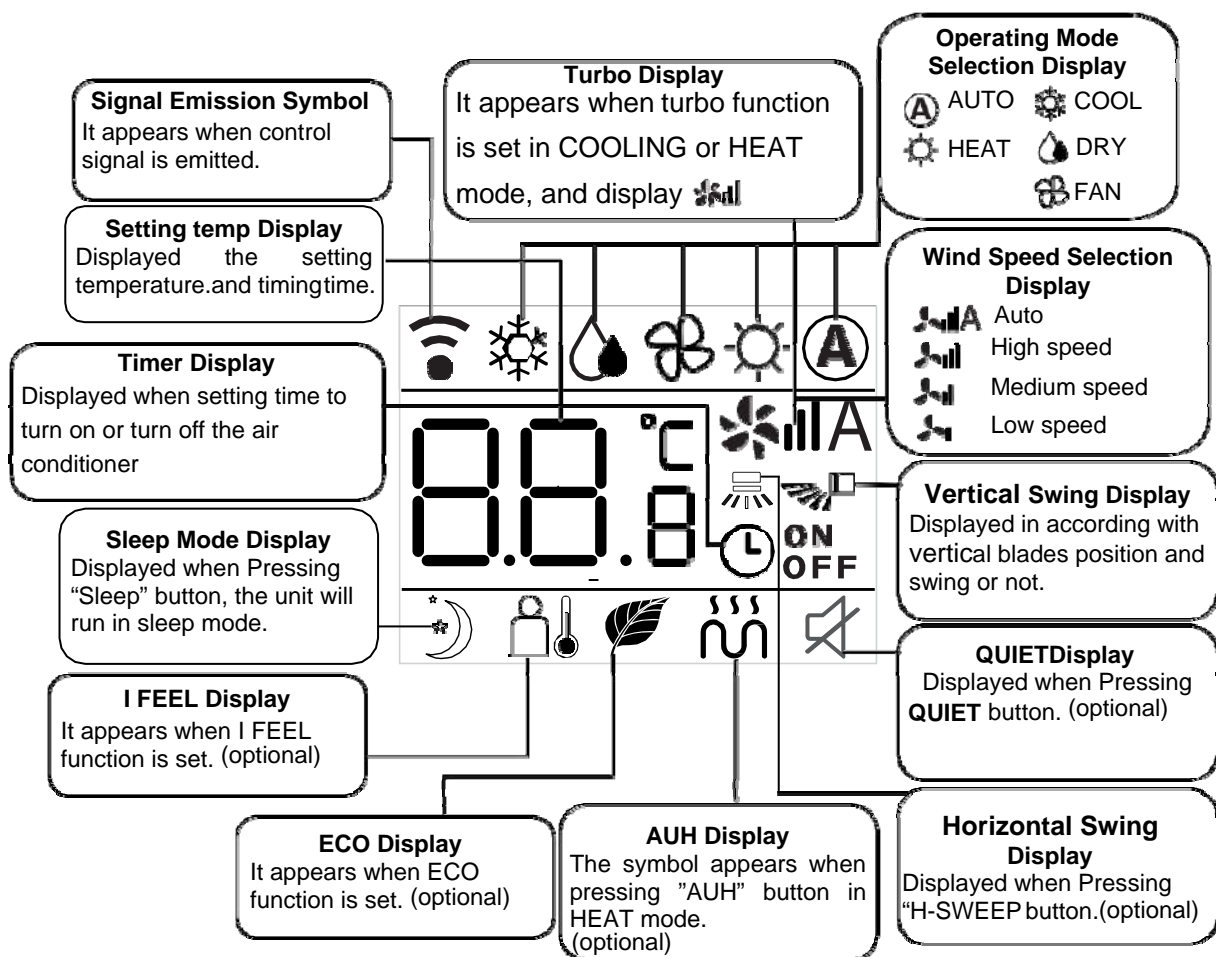

### Instruction for remote controller

- The remote controller uses two AAA alkaline batteries under normal condition, the batteries last for about 6 months. Please use two new batteries of similar type (pay attention to the poles in installing).
- When using remote controller, please point the signal emitter towards indoor unit receiver; There should be no obstacle between remote controller and indoor unit.
- Pressing two buttons simultaneously will result wrong operation.
- Do not use wireless equipment (such as mobile phone) near indoor unit. If interference occurs because of this, please switch off the unit, pull out power plug, then plug again and switch on after a while.
- There is no direct sunlight to the indoor receiver, or it can not receive the signal from the remote controller.
- Don't cast the remote controller.
- Don't put the remote controller under the sunlight or near the oven.
- Don't sprinkle water or juice on the remote controller, use soft cloth for cleaning if it occurs.
- The batteries must be removed from the appliance before it is scrapped and that they are disposed of safety.

## [[ Emergency Run ]]

When the remote controller is missing or the batteries are run out, you can use the Emergency Button.

### Operation Method:

Under the "OFF" condition, open the front board and press Emergency Button with the tip end of a ball-pen or the like and the Air conditioner will operate in "AUTO" mode. Press Emergency Button again to switch off the unit.

## [[ How to Adjust Air Flow ]]

### Horizontal direction

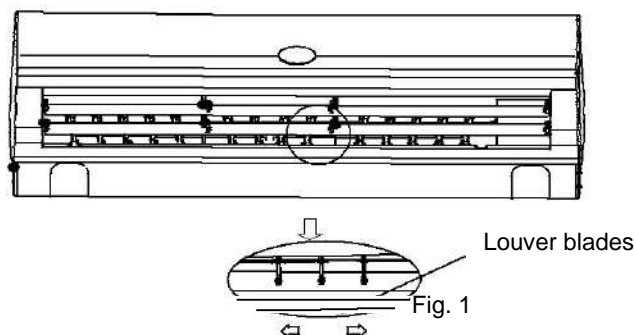

If press the "H-SWEEP" on the remote controller, horizontal louver blades can not swing., please adjust the horizontal airflow direction by hand. (Fig. 1)



### Warning:

Fan inside;  
Keep hands away!

## [[ Sleep Operation ]]

1. When air conditioner is on status, press "SLEEP" button to enter "SLEEP" mode, and  will display on the remote controller.
2. Press "SLEEP" button again,  will disappear on the remote controller, and the sleep (energy saving) function will be cancelled.

### Note:

- 1.Function a: In sleep mode, the set temperature will be increased after running 1 hour in cool and DRY mode; it will be decreased after running 1 hour in heating mode. The set temperature will be controlled between 16°C and 32°C. When air conditioner is in sleep mode, the highest indoor fan speed is set at medium level, but user can change the fan speed by remote controller.
- 2.Function b: In sleep mode, the set temperature and the indoor fan speed will not change ,but the display screen of air conditioner will shut off except for the "RUN" indicator.
- 3.Function a or function b is optional, and it is designed already before the product is dispatched from manufactory.

## SERVICE AND MAINTENANCE

Careful maintenance and overhaul in advance can prolong the air conditioner's service life and save electricity charges.

**Caution:**

1. Stop air conditioner by remote controller and pull off the plug before service and maintenance.
2. Do not stand on unstable objects when you clean or service air conditioner, or it may cause personnel injury.
3. Do not touch the metal part of the body when you remove the front panel, or it may cause personnel injury.



### 〔Clean the Front Panel and Remote Controller〕

If the dirt can't be removed, please clean it with warm damp cloth (soaked with warm water below 40°C)

**Caution:**

1. Do not clean the unit with water, or it may cause electric shock.
2. Do not clean the remote controller with water.
3. Do not clean with alcohol, gasoline, banana oil, or polishing.
4. Do not clean the unit violently, or it may cause the front panel falling down.
5. Do not clean the front panel or remote controller with metal brush; it may damage the surface.



### 〔Clean Air Filter〕

1. Open the front panel. (Fig.4)
2. Lift the protruding part, then pull it downward, remove the air filter.
3. Clean it with vacuum cleaner or water. If air filter is very dirt, please clean it with warm soapy water or mild detergent. Then dry it in the shadow.
4. Insert air filter into the previous position, and close the front panel.

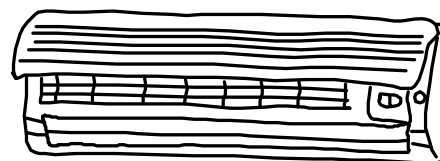

Fig. 4

**Note:**

1. Air filter should be cleaned at least once every two weeks, or heating or cooling capacity will be reduced.
2. Do not clean the air filter with metal brush; it may be damaged.



〔No Use for Long Time〕

1. Swing 3-4 hours to dry the internal air conditioner.



2. Stop operation by remote controller, then cut off the power source of air conditioner.

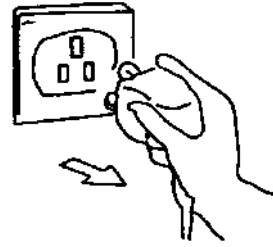

3. Maintain air filter net.

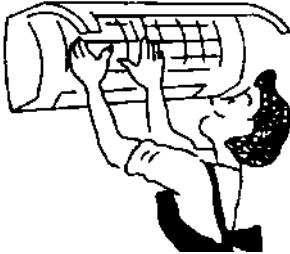

4. Take out batteries from remote controller.

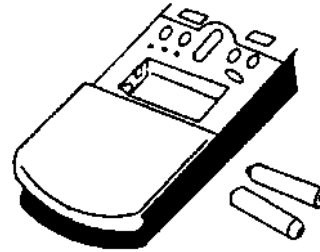

〔 Recommendations for Energy Saving 〕

**Appropriate Temp Setting**

It is harmful to health if the room is too cold.

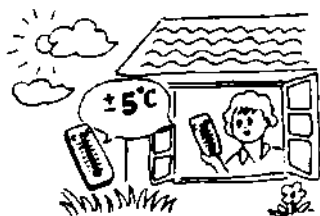

**Avoid Direct Sunlight**

When it is cooling, please use curtain or blind to obstruct direct sunlight.

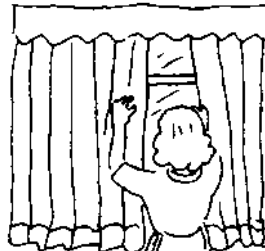

**Avoid Heat Sources**

When it is cooling, using other heat sources may affect cooling effect.



**Close Doors and Windows**

Incoming outdoor air will affect the cooling or heating efficiency.



**Keep Air Filter Clean**

Keeping air filter clean ensures high efficiency operation.

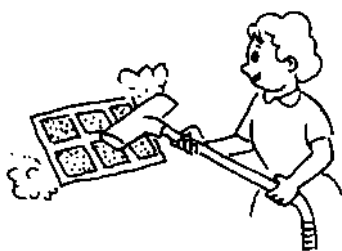

**Good Ventilation**

Do not put objects in front of the inlet and outlet of outdoor unit.

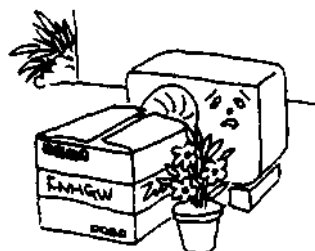

## TROUBLE SHOOTING

### [[ Air Conditioner is in Error ]]

**Checking before service.**

Phenomenon	Checking Items
Air Conditioner Does Not Operate At All	1. Check whether the power is disconnected.
	2. Check whether the breaker is switched on or the fuse is burnt.
	3. Check the remote controller batteries.
	4. Check whether radio equipment is used within 1m around the unit.
Poor Cooling or Heating Performance	1. Check whether the air inlet or outlet is blocked.
	2. Check whether dust is blocking the filter.
	3. There may be too many people indoors.
	4. Check whether doors or windows are closed.
	5. Check whether fan speed or set temperature is improper.

### [[ Remote Controller is in Error ]]

**The following “trouble shooting” is normal phenomenon**

Phenomenon	Checking Items
Fan stops or fan speed can not be controlled.	1. When air conditioner is in DRY mode or SLEEP mode, fan speed can't be controlled sometimes.
	2. When air conditioner is in COOL AIRFLOW PROOF or DEFROSTING operation (in HEAT mode), fan motor will stop.
	3. When air conditioner is in COOL or DRY mode, if air conditioner enters freeze-prevention operation, then fan speed can not be controlled.
	4. When air conditioner is in HEAT mode, if air conditioner enters heating overload prevention operation, then fan speed can not be controlled.

# NORMAL PHENOMENONS

When it is heating or cooling, plastic substance may give out a sound because of the temperature change.



If the indoor humidity is too high, water drops may form on the front grill of indoor unit. This is a normal phenomenon.

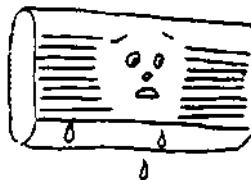

There may be gentle "rustle" sound when the unit starts or stops. It is the normal sound of flowing refrigerant.



Walls, carpet, furniture or clothes indoors may disseminate peculiar smell.



In order to protect the unit, when the compressor stops, there will be a 3-minute delay before restarting.

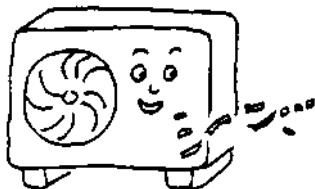

In the first several minutes of heating operation, wind may not come out from the indoor unit.



Water may flow out from the outdoor unit during heating operation.

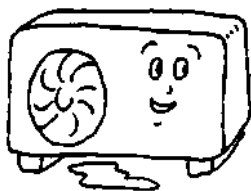

In heating operation, steam may come out when it is defrosting.

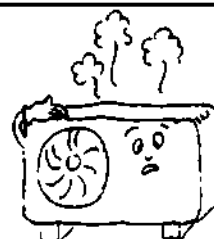

---

# INSTALLATION MANUAL

## 〔Installation Guide〕

- This air conditioner meets the safety and operation standards promulgated by the Nation.
- You need to invite professional air conditioner service and maintenance personnel to install or remove the air conditioner. Problems may occur and you may suffer losses if non- professionals install the air conditioner.
- User shall provide the power that meets installation and operation requirements. please refer to nameplate for details about the voltage for this product. Voltage beyond this scope will affect the normal operation of the air conditioner.
- Separate power point with delay fuse protector or automatic breaker should be used for the air conditioner.
- The air conditioner must be correctly and reliably grounded, or it may cause electric shock or fire.
- Do not switch on the power of the air conditioner before well connecting and carefully checking the tubing and wires.
- The appliance shall not be installed in laundry or bathroom.
- In case necessary, please consult your supply authority for system information.
- The plug shall be accessible after installed the appliance.
- This instruction is subject to change without notice.

## 〔Installation of Accessories〕

- Examine carefully the attached packing list and check whether the accessories are complete.
- Users may need to buy at their own expenses the articles not included in the packing list and may be needed in installing.

## 〔Position for Indoor Unit〕

- Away from the place where there is heat source, steam source, leakage of flammable gas and smoke.
- No obstacles near the inlet and outlet, and keep good ventilation.
- Good discharge for water.
- At least 1m away from wireless equipment (such as TV, radio etc.).
- Mounted on the wall that can bear the weight of the air conditioner and won't produce noise while unit working.

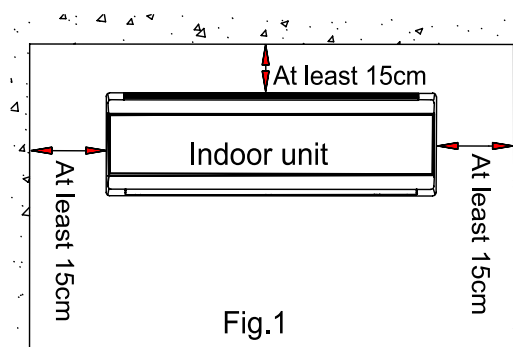

- The distance between the indoor unit and the floor should be greater than 2.3m.
- The plug shall be accessible after installing the appliance.
- Ensure the distance as required in Fig.1.
- The back of the indoor unit should be close to the wall(Fig.1)
- The all figures are only schematic, and they may be slightly different from the actual appliances you selected.

## [[ Position for Outdoor Unit ]]

- Avoid direct sunlight.
- Away from heat source, steam source, leakage of flammable gas, smoke and dust.
- Select a place that is away from rain (snow) and has good ventilation.
- Neighbors will not be affected by the blown wind and noise, or discharged water.
- The place that is easy to install and service.
- Mounted on the solid and reliable foundation will not increase noise or shock.
- To get high cooling performance, make sure the unit's front, rear, left and right sides must be located in an open area.
- The outlet is proposed to be in open air, any obstacle will affect the performances.
- The installing distance must be required as Fig. 2 shows.

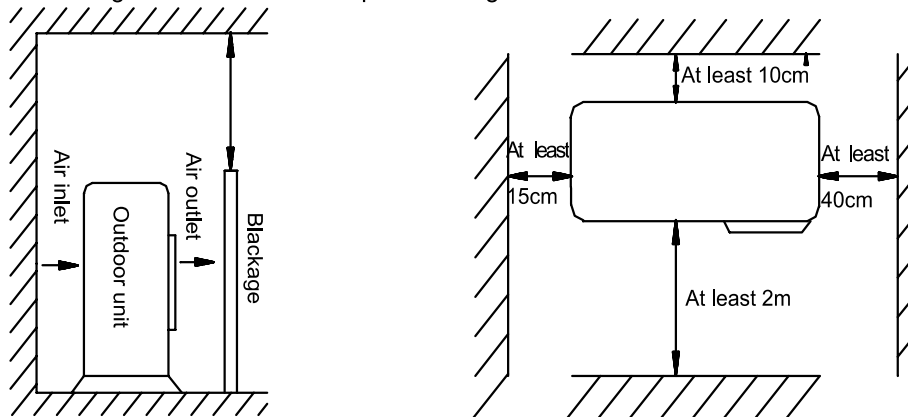

Fig.2

## [[ Tubing Selection ]]

- Ensure that the level (height) difference of indoor and outdoor units and the length of tubing meet the requirement In the Table 1.
- If the tubing is longer than 7m, but shorter than 20m, refrigerant should be supplemented according to Table 1.
- If the installation position of the outdoor unit is higher than indoor unit and the tubing is longer than 10m, added a oil trap on the gas tubing for every 8m. (Fig.3)

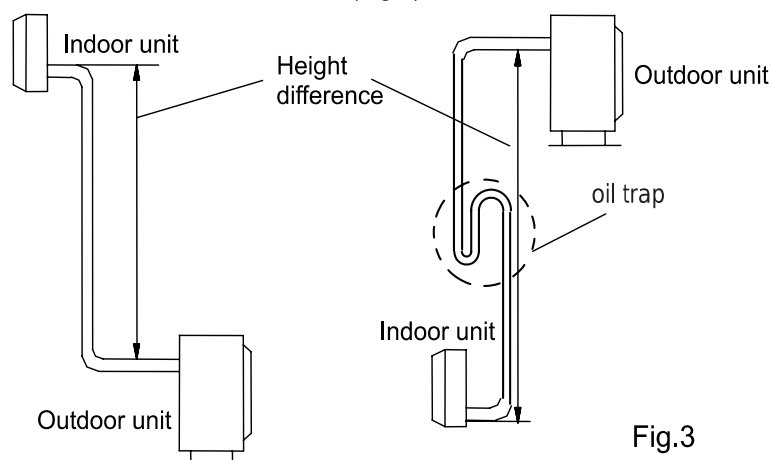

Fig.3

Tabel 1

Tubing size(mm/inch)		Standard tubing Length (m)	Max tubing Length (m)	Height Difference (m)	Additional refrigerants(g./m)
Liquid tube	Gas tube				
φ 6(1/4")	φ 9.52(3/8")	5.0	9	5	12
φ 6(1/4")	φ 12(1/2")	5.0	12	7	12
φ 6(1/4")	φ 15.88(5/8")	5.0	15	8	12
φ 9.52(3/8")	φ 15.88(5/8")	5.0	15	8	15
φ 9.52(3/8")	φ 19.05(3/4")	5.0	20	10	15

The above dimensions are for reference only, the actual product shall prevail"

### 〔 Fixing Installation Panel 〕

- Dismantle the metal installation board of the indoor unit. Adjust the installation board to horizontal position. The height difference between the left and right sides of the installation board should be less than 5mm.( Fig.4 )
- Drill holes and insert plastic expansion tubes at the appropriate locations on the wall and fix the installation board on the wall with M5x30 screws . Ensure that there must be at least 4 fixed points in the wall. Ensure installation board to horizontal position.
- Drill holes as Fig.5 shows. The hole, 80mm in diameter, should slightly slide down outwards..
- Cut PVC tubes at a slight angle in the length shorter than wall thickness and inset it into the hole.( Fig.5 )
- Mount the wall cap.

left side right side

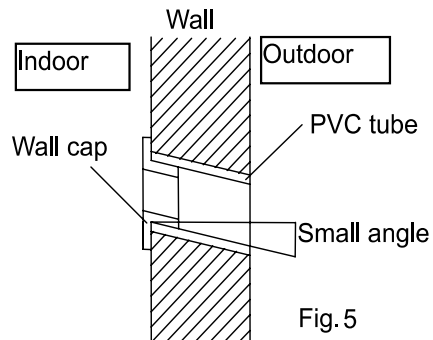
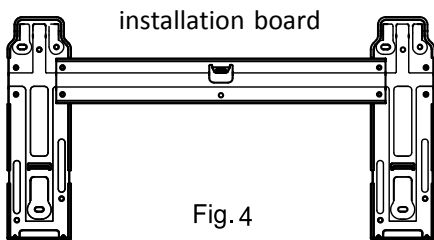

left side right side

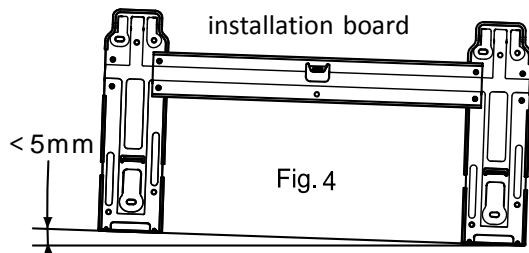

horizontal direction

left side right side

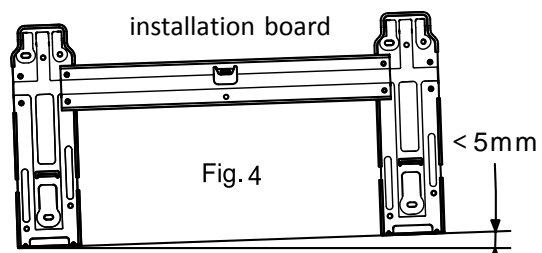

horizontal direction

# Attachment: installation instructions for decorative cover plate

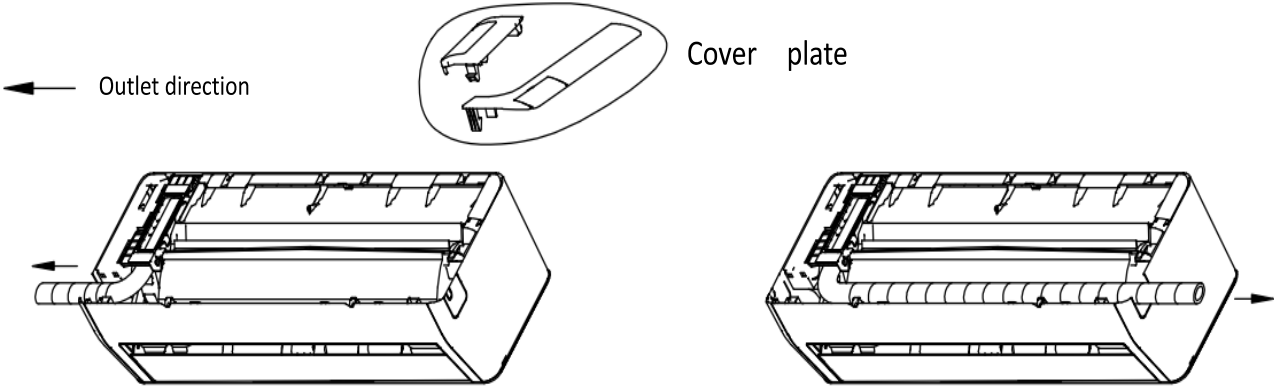

STEP1: Wrap PVC protective tape around drainage pipe, copper pipe and cable.  
Adjust the copper pipe tube to a suitable shape.

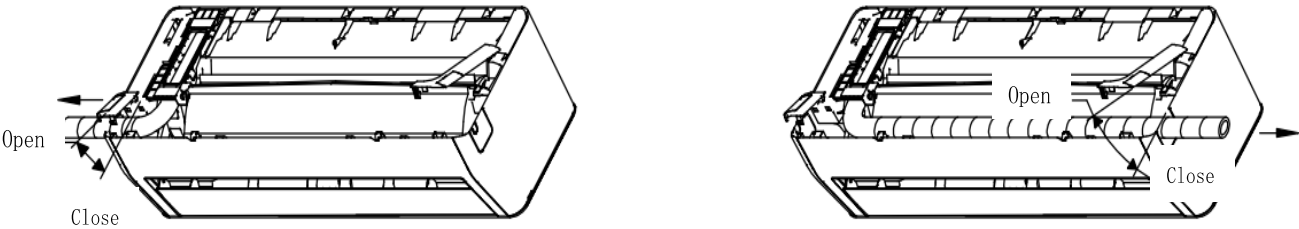

STEP 2: Install the cover plate





## 〔Indoor Unit Installation〕

The tube may be connected in several directions as below shown Figures.

1. Connecting right back tube (similar to right lower tube) (Optional, Refer to Fig.6)

- Pull out the tubing from bottom of the chassis; and connect the drainpipe. Strap the joint of tubing reliably.
- Lead the connecting wire to the indoor unit (Do not connect to the power).
- Strap together the tubes, discharge pipe and connecting wire with adhesive tape. The discharge pipe is put at the below.
- Remove the board which is on the chassis.
- Check if the connections are reliable.
- Mount the indoor unit on the two hooks at the upper part of installation board. (refer to Fig.8)

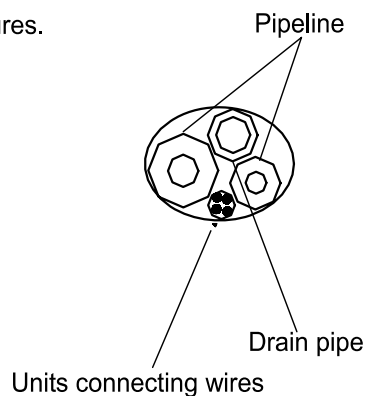

Fig.6

2. Connecting left back tube (similar to left lower tube). (Optional, Refer to Fig9)

- Move the discharge tube to the left side, and discharge cap to the right side.
- Fix the tubes in the slot of the indoor unit with the fix clamp.
- The following mounting steps are the same as those in “1. Connecting right back tube.”

Notes: Left chart is available for the position of drain hose, refer to Fig.7.

Right chart is available for the position of drain hose, refer to Fig.9.

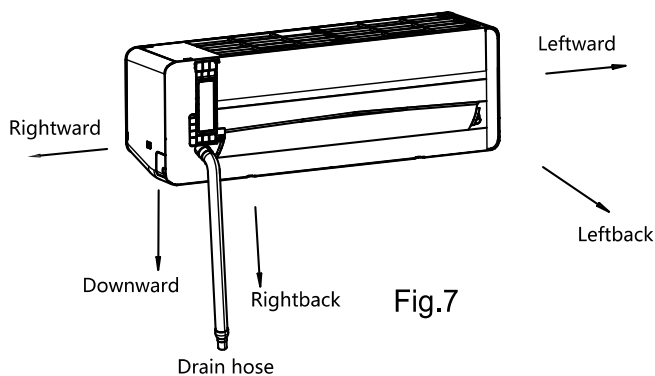

Fig.7

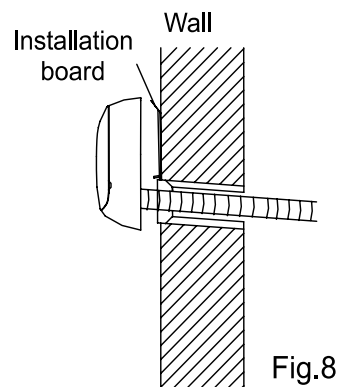

Fig.8

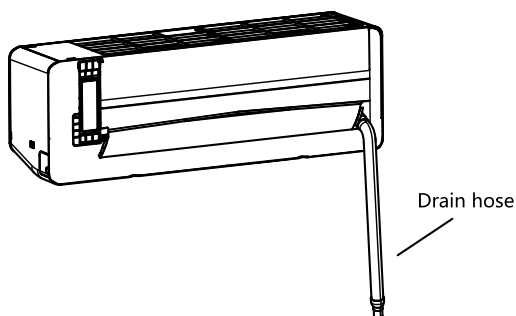

Fig.9

## [[ Outdoor Unit Installation ]]

- If installation brackets for installing outdoor unit are needed, user could buy the brackets from our company or agents (Fig.10) .
- Assemble the mounting frame and supports with the attached 6 screws , plain washers, spring washers, and nuts.
- Drill 6 or more holes on the wall according to the feet size of the air conditioner. Determine the locations for mounting left and right supports. Ensure that the left and right supports are on the same level.
- Fix installation frame on the wall with expansive bolts.
- Fix outdoor unit with 4 bolts on the installation brackets.
- Fittings must be tightly screwed; Connection must be tight and reliable.
- In installing outdoor unit, the body should be hung with ropes to prevent from falling.
- In installing or repair, tools and components should be prevented from falling.
- Regularly check the reliability of the installation frame.

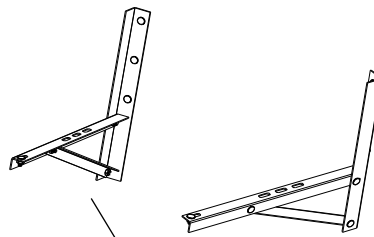

Fig.10

Installation support

## [[ Tubing Connection ]]

- Detach the valve cover of outdoor unit.
- Align flaring nut to the thread center, and screw the nut tightly by hand.
- Screw tightly the flaring nut with torque spanner until the torque spanner produces "click" sound.
- It is recommended to use torque spanner to connect the tubing. If other flexible or fixed spanner is used, it may damage the horn mouth due to improper force.
- The bending angle of the tube should not be too small or the tube may break up, so the service personnel should use tube bender to bend the tube.
- Never let water, dust or sand gets into the pipe.

**Table 2**

Tubing size (mm/inch)	Torque (N. m)
φ 6 (1/4")	15~20
φ 9.52(3/8")	35~40
φ 12(1/2")	50~55
φ 15.88(5/8")	60~75
φ 19.05(3/4")	80~95

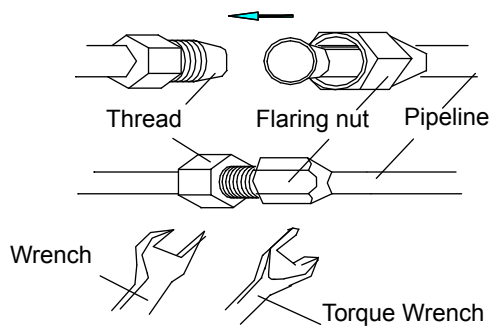

Fig.11

## 〔 Connection of Wires 〕

### 1. Indoor unit

- Open upward the inlet grid to the greatest extends.
- Remove the electric cover from the unit.
- Loose the screw at connection lid. (Fig.12)
- Dismantle the wire pressure plate.
- Connect the power connecting wires and signal control wire separately to the corresponding terminals. (In Fig.14, please choose the same wiring diagram just with the wiring diagram of unit .)
- Loose off the screw on the earth plate; press earth wire tightly.
- Press tightly the connecting wires of the unit with lead wire pressure plate.
- Close the connection lid screw it tightly and close the inlet grid.

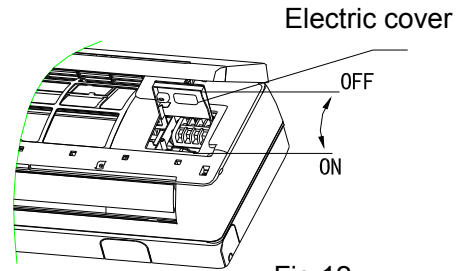

Fig.12

### 2. Outdoor unit

- Unscrew and dismantle the electronic device lid(Fig.13).
- Dismantle the pressure plate of wire fastener.
- Connect the connecting wires of the unit separately to the corresponding terminals. (Fig.14)
- Press tightly the connecting wires of the unit with top pressure plate.
- Remount the electronic device lid to the original position.

If user wants to prolong or replace the power wire, please do it according to the table(Table3).

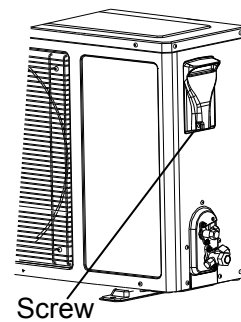

Fig.13

Table 3

		Power connecting wires	Signal control wire	Power cord
	Max. Length	10m	10m	5m
5K/7K/9K/12K	Cross sectional area	$\geq 1.0 \text{ mm}^2$	$\geq 1.0 \text{ mm}^2$	$\geq 1.0 \text{ mm}^2$
16K/18K		$\geq 1.5 \text{ mm}^2$	$\geq 1.5 \text{ mm}^2$	$\geq 1.5 \text{ mm}^2$
18K/21K/24K/28K		$\geq 2.5 \text{ mm}^2$	$\geq 0.75 \text{ mm}^2$	$\geq 2.5 \text{ mm}^2$

---

Connecting diagram for 7K,9K,12K,18K,24K.

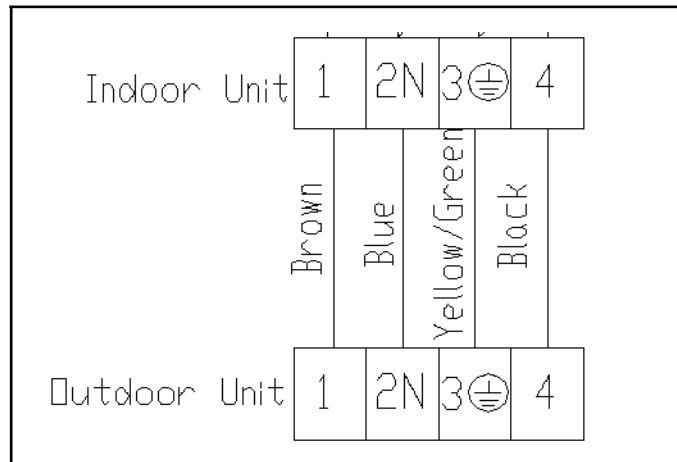

Fig.14

---

## Notes:

- Earthing screw must use special screw(stainless machining screws or copper screws M4)
- Ensure that all wires are securely connected, will not loose or separate.
- Ensure that wire connections are carried out according to the wiring diagram of the air conditioner.
- The above figures are only schematic, and they may be slightly different from the actual appliances you select.

## Tube Strapping

- Strapping with PVC Protective tape must be careful, do not damage the pipeline and drain pipe.
- Strapping should start from the lower part of the outdoor unit to the indoor unit.
- Fix the PVC tape with adhesive tape to prevent loosing.
- Drainpipe should slightly slide down outwards to ensure drainage well.
- When the indoor unit is lower than the outdoor unit, bend the tube to proper extent to prevent water draining into house.
- Fix the tube bundle with tube clamps on the wall.
- Allow enough space between discharge pipe and the ground. Do not put the discharge pipe in water or ditch.
- Seal the external wall holes with sealing gum or putty.

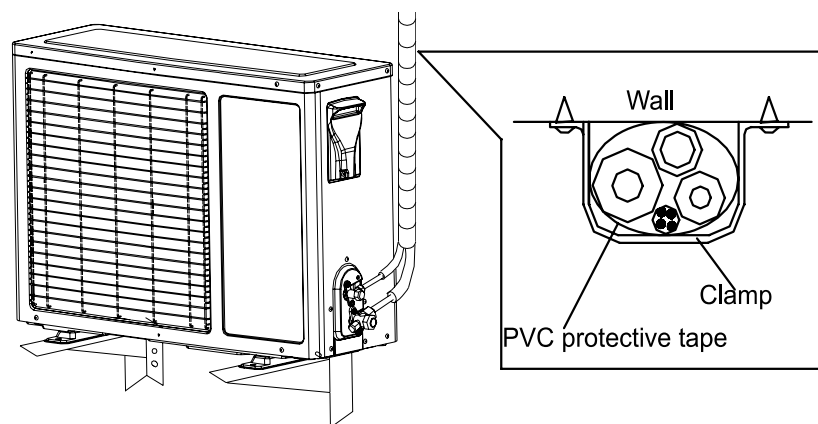
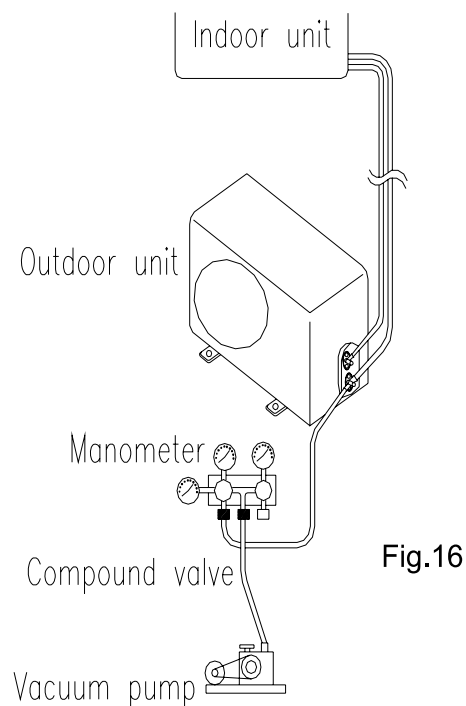

Fig.15

---

## Pumping type

- Make sure that all the tubes of indoor and outdoor unit are connecting well.
- Take off valve bonnet from two-way and three-way valves by spanner; connect vacuum pump and compound valve to the service valve bonnet.
- Open the low-pressure switch of compound valve, and run vacuum pump until units' internal pressure at 10 mmHg.
- After pump vacuum, close the low-pressure switch of compound valve, and then close vacuum pump. Turn anti-clockwise 90° Spool of narrow pipe service valve by hexagon spanner, tightly with clockwise turning after stopping for 10 seconds.
- Check with soap water or leak detector whether there is leakage at all connections of indoor and outdoor unit.
- Open wide and narrow pipe service valves by hexagon spanner for running.
- Take off the connection pipeline of wide pipe service valve.
- Screw tightly the entire valve bonnet by torque spanner.
- Check with soap water or leak detector whether there are leakage at all indoor and outdoors' connections.
- Put the valve bonnet and lid back to position.



---

## [ Drainage ]

### 1. No need drainage treatment

In regions where become cold in the winter, don't install the drain elbow joint to prevent drain water from freezing and causing the fan to be damaged. This drainage treatment is not necessary for cooling-only type air conditioner.

### 2. When need drainage treatment

- Please use drain elbow joint (in accessory bag). Outdoor unit should be placed on blocks.

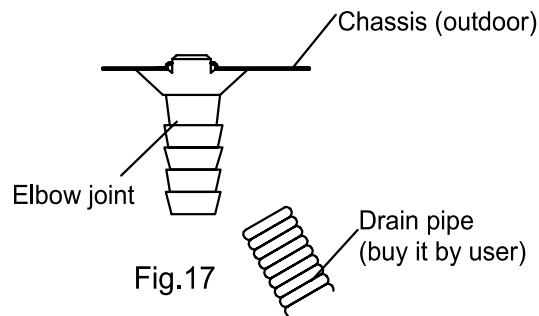

Installation for the cover of valve:

For the whole unit that individual cover of valve is available (refer to packing list), the installing method is as follow:

After connecting the connection pipes between indoor and outdoor units followed by the installing method mentioned above, take out the cover of valve from the accessory bag, and fix it on the side of outdoor unit with three corresponding screws ( inside the accessory bag ).

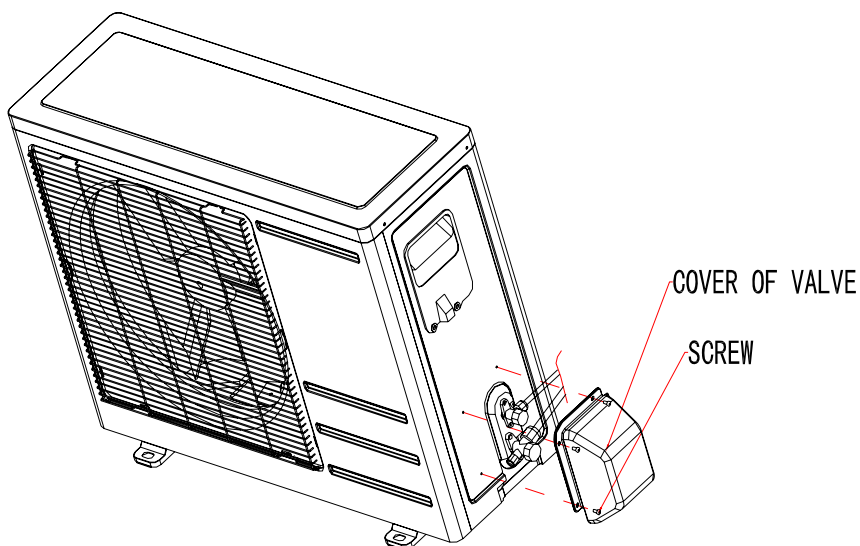

Fig.18

## PRECAUCIONES DE SEGURIDAD



**ADVERTENCIA: Seguir estas precauciones básicas reducirá la riesgo de incendio, descarga eléctrica, lesiones o muerte al usar su aire acondicionado.**

1. El acondicionador de aire debe estar conectado a un tomacorriente o disyuntor adecuado con la suministro eléctrico. Y solo se puede usar la potencia especificada.
2. Se debe garantizar una conexión a tierra adecuada para reducir el riesgo de descarga eléctrica e incendio.

**NO HAGACORTE O QUITE LA CLAVIJA DE PUESTA A TIERRA.** Si no tiene una de tres puntas tomacorriente o disyuntor en la pared, solicite a un electricista certificado que instale el receptáculo o disyuntor. El receptáculo de pared o el disyuntor DEBEN estar correctamente conectados a tierra.

3. **NO HAGAUtílcelo** si el cable de alimentación está deshilachado o dañado. También evite usarlo si hay grietas o daños por abrasión a lo largo de la longitud, el enchufe o el conector.

4. **NO HAGAUUTILICE UN ADAPTADOR O UN CABLE DE EXTENSIÓN.**

5. **NO HAGAbloquee** el flujo de aire dentro o fuera del acondicionador de aire con persianas, cortinas, protectores cubre, arbustos o colorete.

6. Tenga cuidado con los bordes afilados de las aletas delantera y trasera de la unidad que podrían cortar y causar lesion grave.

7. Tenga cuidado al levantar el acondicionador de aire para instalar o quitar la unidad. Utilice siempre dos o más gente por esto.

8. Siempre desconecte la energía del acondicionador de aire antes de repararlo o moverlo.

9. En algunos tipos de unidades, no hay un enchufe apropiado correspondiente a su cable de alimentación debido a energía, bajo esta condición, un disyuntor de energía apropiado debe estar conectado a su cable de alimentación, por lo tanto, la parte de instrucciones asociada con el uso del enchufe no está disponible para estos tipos.



# CONTENIDO

## 1. INSTRUCCIONES DE SEGURIDAD

Símbolo Descripción.....	2
Instrucciones de instalación.....	2
Instrucciones de funcionamiento.....	3
Instrucciones de seguridad.....	6

## 2. INTRODUCCIÓN DEL PRODUCTO

Funciones de protección.....	7
------------------------------	---

## 3. DESCRIPCIÓN DE LOS COMPONENTES

Vista de la unidad.....	8
Pantalla de visualización.....	9
Control remoto.....	10
Pantalla del control remoto.....	11

## 4. SERVICIO Y MANTENIMIENTO

Limpiar el Panel Frontal y el Control Remoto.....	13
Limpiar el Filtro de Aire.....	13
Sin uso durante mucho tiempo.....	14
Recomendaciones para el Ahorro Energético.....	15

## 5. RESOLUCIÓN DE PROBLEMAS

El acondicionador de aire tiene un error.....	16
El control remoto tiene un error.....	dieciséis

## 6. FENÓMENOS NORMALES.....17

## INSTRUCCIONES DE SEGURIDAD

### 〔Símbolo Descripción〕

	<b>Advertencia:</b>	Un símbolo que indica una operación que puede causar bajas personales o daños graves.
	<b>Precaución:</b>	Un símbolo que indica una operación que puede causar bajas personales o daños a la propiedad.

### 〔Instrucciones de instalación〕

**Advertencia**

**— Nunca lo instale usted mismo.**

El acondicionador de aire tipo split funcionará durante un largo período de tiempo si está instalado correctamente.

Una instalación incorrecta podría causar problemas como fugas de agua o refrigerante, descargas eléctricas o incendios.

**Precaución**

**Confirme lo siguiente antes de la instalación**

<p><b>— Especificaciones de potencia</b></p> <p>Asegúrese de que la capacidad del enchufe o disyuntor y el cable de alimentación sea suficiente, el voltaje sea correcto y el enchufe o disyuntor esté conectado a tierra. De lo contrario, puede haber peligro de incendio o descarga eléctrica.</p>	<p><b>— Conexión adecuada de cables y tuberías</b></p> <p>Una conexión incorrecta puede disminuir la eficiencia o hacer que el aire acondicionado deje de funcionar. También se pueden producir fugas de agua o refrigerante.</p>
<p><b>— Entornos de instalación</b></p> <p>No instale el acondicionador de aire en un lugar donde haya aire inflamable o corrosivo.</p>	<p><b>— Instrucciones de operación</b></p> <p>Utilice el acondicionador de aire de acuerdo con este manual.</p>

〔Instrucciones de operacion〕

**ADVERTENCIAS**

Seguir los mensajes de seguridad es muy importante. Estos mensajes pueden salvarlo de ser herido o muerto. Los símbolos de advertencia le advierten que tenga cuidado y significan peligro. Siga siempre las instrucciones para estar seguro y reducir las posibilidades de lesión o muerte. Las señales de advertencia y peligro precederán a los mensajes de seguridad.

**Seguridad ELECTRICA**

**Toma de tierra:** Este acondicionador de aire de habitación debe estar conectado a tierra.



La conexión a tierra reduce el riesgo de descarga eléctrica al proporcionar un cable de escape para el corriente eléctrica.

Si el cable de alimentación tiene un enchufe de conexión a tierra con un cable de conexión a tierra, conéctelo a un tomacorriente que esté correctamente instalado y conectado a tierra.

Si el cable de alimentación no tiene un enchufe de conexión a tierra con un cable de conexión a tierra, el cable de conexión a tierra debe conectar el disyuntor que esté correctamente instalado y conectado a tierra.

**Advertencia:** El uso inadecuado del enchufe o disyuntor de conexión a tierra puede resultar en un riesgo de descarga eléctrica.

Llame a un electricista calificado si no comprende las instrucciones de conexión a tierra o si no está seguro de si el acondicionador de aire está correctamente conectado a tierra. Si el tomacorriente de pared o el disyuntor no está conectado a tierra, comuníquese con un electricista para que lo reemplace por un tomacorriente o disyuntor correctamente conectado a tierra.

**Bajo ninguna circunstancia, corte o extraiga la tercera clavija (tierra) del cable de alimentación.**

**Enchufe adaptador:** Le recomendamos encarecidamente que no utilice un enchufe adaptador o un disyuntor.

**Condiciones de operación**

1. Temperatura: instancia T1: -7°C~43°C(dieciséis°C~43°Cen el tipo de solo enfriamiento)

Instancia T3: -7°C~52°C(dieciséis°C~52°Cen el tipo de solo enfriamiento)

Si la unidad funciona por encima de la temperatura durante mucho tiempo, puede causar que la capacidad de enfriamiento disminuya o que el protector funcione.

2. Humedad relativa: <80%

Si la unidad funciona más allá del rango de humedad, se puede formar condensación cerca del aspa y la salida del acondicionador de aire. Es normal.

3. En la operación de calefacción, puede salir un olor extraño de la unidad. Es un fenómeno normal.

4. Los parámetros de rendimiento se refieren a la placa de identificación.

5. El nivel de impermeabilidad de la unidad interior es IPX0. No lo use en la lavandería o el baño.

6. La unidad exterior no se puede instalar en un área cerrada.

7. Fusible: T3.15AL250V, corriente nominal: 3.15A.

**Puntas**

- Instale la unidad en el lado norte, ya que normalmente es el lado sombreado. Esto mejorará el funcionamiento de su unidad.
- Use el voltaje eléctrico correcto y el amperaje adecuado para que la unidad funcione de manera efectiva. Solo permita que un electricista certificado haga cualquier modificación a su toma de corriente o disyuntor.
- Utilice una línea dedicada para el funcionamiento de su acondicionador de aire para evitar la posibilidad de una sobretensión eléctrica.
- Si el cable de alimentación está dañado, debe ser reemplazado por el fabricante o su agente de servicio o una persona calificada similar para evitar un peligro.
- Las dimensiones del espacio necesario para la correcta instalación del aparato, incluidas las distancias mínimas permitidas a las estructuras adyacentes.
- El aparato se instalará de acuerdo con las normas nacionales de cableado. Desconecte la fuente de alimentación antes de la limpieza y el mantenimiento.
- Si el aparato no está conectado por enchufe, un dispositivo de desconexión de todos los polos que tenga una distancia de separación de al menos 3 mm en todos los polos y un dispositivo de corriente residual (RCD) con una clasificación superior a 10 mA se incorporará en el cableado fijo de acuerdo con la norma nacional.
- Si el aparato está conectado por enchufe, debe colocarse de manera que se pueda acceder al enchufe.

**Guía de ahorro de energía**

- Cuando instale su acondicionador de aire, asegúrese de sellar todas las áreas donde exista la posibilidad de fugas de aire.
- El flujo de aire no debe bloquearse en el interior, ya sea por cortinas, cortinas o muebles, ni en el exterior por arbustos o arbustos.
- No utilice innecesariamente una luz eléctrica u otros aparatos que produzcan calor. Mantenga las persianas y las cortinas cerradas en todas las demás ventanas.
- Mientras cocina, use un extractor de aire en la cocina para eliminar el exceso de calor producido.

〔Instrucciones de operacion〕

Solo se puede utilizar alimentación de CA monofásica. por favor refiérase a la placa de identificación para más detalles.

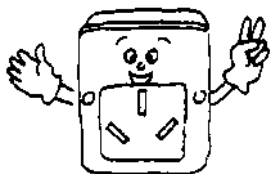

Utilice el cable de alimentación especificado; no lo cambie

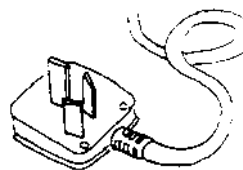

No introduzca los dedos ni palos en la entrada o salida del acondicionador de aire; el ventilador en funcionamiento puede causar lesiones.

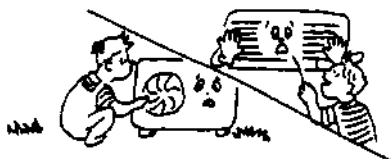

No coloque nada sobre la unidad exterior.



No encienda o apague la unidad enchufando o tirando del enchufe, o encendiendo o apagando el disyuntor.



Mantenga el interior ventilado, especialmente cuando haya equipos de gas en funcionamiento.



No sustituya el fusible por cable conductor u otros materiales.



Desconecte el enchufe o apague el disyuntor si el acondicionador de aire no se usa durante mucho tiempo.

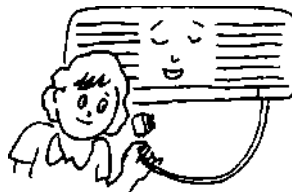

【Instrucción de seguridad】



**El aparato no está diseñado para ser utilizado por niños pequeños o personas enfermas sin supervisión.**  
**Los niños pequeños deben ser supervisados para asegurarse de que no jueguen con el aparato.**  
**Si el cable de alimentación está dañado, debe ser reemplazado por el fabricante o su agente de servicio o una persona calificada similar para evitar un peligro.**

**Advertencia:**

No conecte la línea de tierra a la tubería de gas, tubería de agua. Una conexión a tierra inadecuada puede causar una descarga eléctrica.

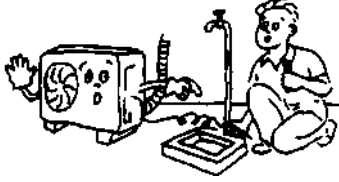

No desconecte el enchufe ni apague el interruptor cuando esté en funcionamiento.



Apague la unidad; corte la fuente de alimentación y póngase en contacto con el agente de servicio si hay un fenómeno anormal (por ejemplo, sale olor a quemado).



No instale el acondicionador de aire en un lugar donde pueda haber fugas de gas inflamable.

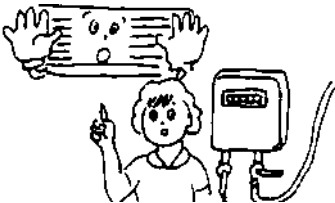

No coloque plantas o animales directamente en el camino del flujo de aire del acondicionador de aire. Hacerlo podría dañarlos.



Póngase en contacto con los agentes de servicio para el servicio. Un servicio inadecuado puede causar un accidente.



Apague la unidad, corte la fuente de alimentación y asegúrese de que el ventilador se detenga antes de limpiar la unidad.

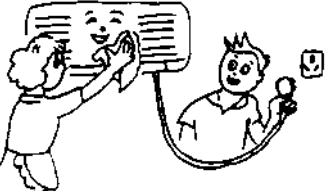

Para la extracción e instalación del acondicionador de aire, consulte a profesionales o póngase en contacto con agentes de servicio.

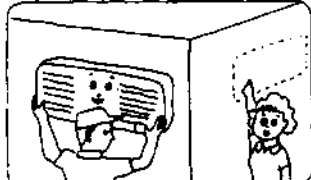

## INTRODUCCIÓN DEL PRODUCTO

### 〔Funciones de protección〕

Las funciones de protección pueden prolongar la vida útil del acondicionador de aire y proporcionar un flujo de aire más cómodo.

#### **Protección de retardo de arranque del compresor**

El compresor volverá a funcionar al menos 3 minutos (5 minutos en modo calefacción) después de apagarse para mantener el equilibrio de presión del sistema de refrigeración.

**Observaciones:** Habrá 1 minuto para que el compresor funcione después de que la unidad se electrifique por primera vez. **Descongelación (no disponible para acondicionadores de aire de tipo solo refrigeración)**

El intercambiador de calor exterior puede congelarse si la temperatura exterior es baja y la humedad es alta. En este caso, la descongelación automática ha funcionado durante 3 a 10 minutos. el indicador de pausa estará encendido, los ventiladores interior y exterior se detendrán.

#### **Protección de sobrecarga de calefacción (no disponible para acondicionadores de aire de tipo solo refrigeración)**

Cuando la temperatura de la tubería interior es demasiado alta, el aire acondicionado entra en la protección de sobrecarga de calefacción. Y la velocidad del ventilador interior debe ajustarse automáticamente a una marcha más alta. El ventilador exterior y el compresor pueden estar parados. Cuando la temperatura de la tubería interior cae a un valor nominal, el acondicionador de aire saldrá de la protección contra sobrecarga de calefacción. El motor del ventilador interior vuelve al estado normal.

#### **Función de soplado de calor residual (no disponible para acondicionadores de aire de tipo solo refrigeración)**

El ventilador interior seguirá funcionando a baja velocidad durante 80 segundos cuando el aire acondicionado se detenga en el modo de calefacción.

#### **A prueba de flujo de aire de enfriamiento (no disponible para acondicionadores de aire de tipo solo enfriamiento)**

En los primeros minutos de funcionamiento de la calefacción, se enciende el indicador de PAUSA; el ventilador interior no funciona y las aspas de las persianas no se pueden controlar. Aproximadamente 5 minutos más tarde, el aire acondicionado emitirá un flujo de aire caliente, el indicador de PAUSA está apagado.

#### **Prevención de congelamiento**

Para evitar que el intercambiador de calor interior se congele durante la operación de refrigeración y deshumidificación, el compresor o el ventilador exterior pueden dejar de funcionar; la velocidad del ventilador interior se ajustará automáticamente a una marcha más alta.

#### **Seco para la prevención de enzimas (opcional)**

El motor del ventilador interior seguirá funcionando durante 3 minutos a baja velocidad del ventilador cuando se apague en el modo de enfriamiento para mantener seco el interior de la unidad.

#### **Restablecer energía o reinicio automático (alternativa)**

**Restablecer energía:** cuando hay una suspensión eléctrica, el aire acondicionado se apagará automáticamente. Cuando la energía vuelve, la unidad restablecerá automáticamente la energía. Para ahorrar energía, si no hay nadie en la habitación, el aire acondicionado permanecerá en estado de PAUSA. El usuario debe encender el aire acondicionado con el control remoto.

**Reinicio automático:** la unidad memoriza el modo de funcionamiento, la configuración del flujo de aire, la configuración de la temperatura, etc., de modo que si se produce un corte de energía cuando la unidad está en funcionamiento, volverá automáticamente a las mismas condiciones de operación cuando se restablezca la energía.

#### **Funcionamiento de sobrecarga de refrigeración (opcional)**

En la operación de enfriamiento, si la temperatura del intercambiador de calor exterior es demasiado alta, la velocidad del ventilador interior se ajustará automáticamente a una marcha más baja y el compresor puede detenerse.

**A prueba de goteo (opcional)**

En la operación de enfriamiento y deshumidificación, las hojas de las persianas pueden cambiar la posición automáticamente para evitar que gotee.

## DESCRIPCIÓN DE COMPONENTES

〔Vista de la Unidad〕

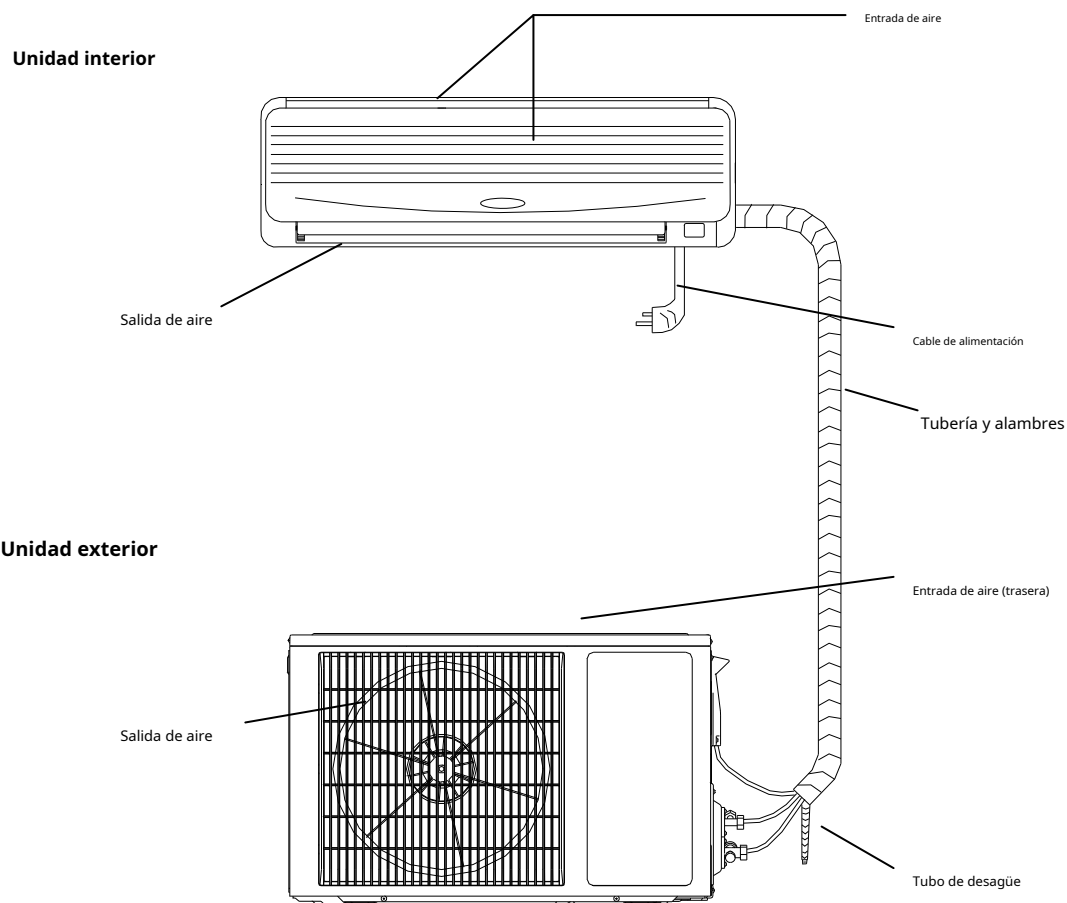

**Observaciones:**

El acondicionador de aire consta de una unidad interior, una unidad exterior y un mando a distancia. El diseño y la forma son diferentes para diferentes modelos. Las cifras anteriores son solo esquemáticas y pueden diferir ligeramente de los aparatos reales que seleccionó.



## [ Display screen ]



**Indicador de salud** Esta luz se enciende cuando la función UV C o el generador de plasma frío están funcionando.



**Indicador de temporizador** : This signal light is on when the unit is in Timer.



**Indicador del compresor** : This signal light is on when the compressor is running



**Indicador WIFI:**Intermitente en nombre de la búsqueda, iluminación en nombre de la conexión WIFI completa, lo que significa que la función WIFI puede ser operación y aplicación. (Para obtener más detalles, consulte el manual de instrucciones de WIFI)"

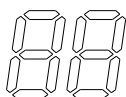

**Indicador de temperatura** : This display can show the set temperature .when the indicator display F4,F1orF2, means the air conditioner runs abnormally

(The above LED display is for reference only, subject to the actual product)

## 【Control remoto】

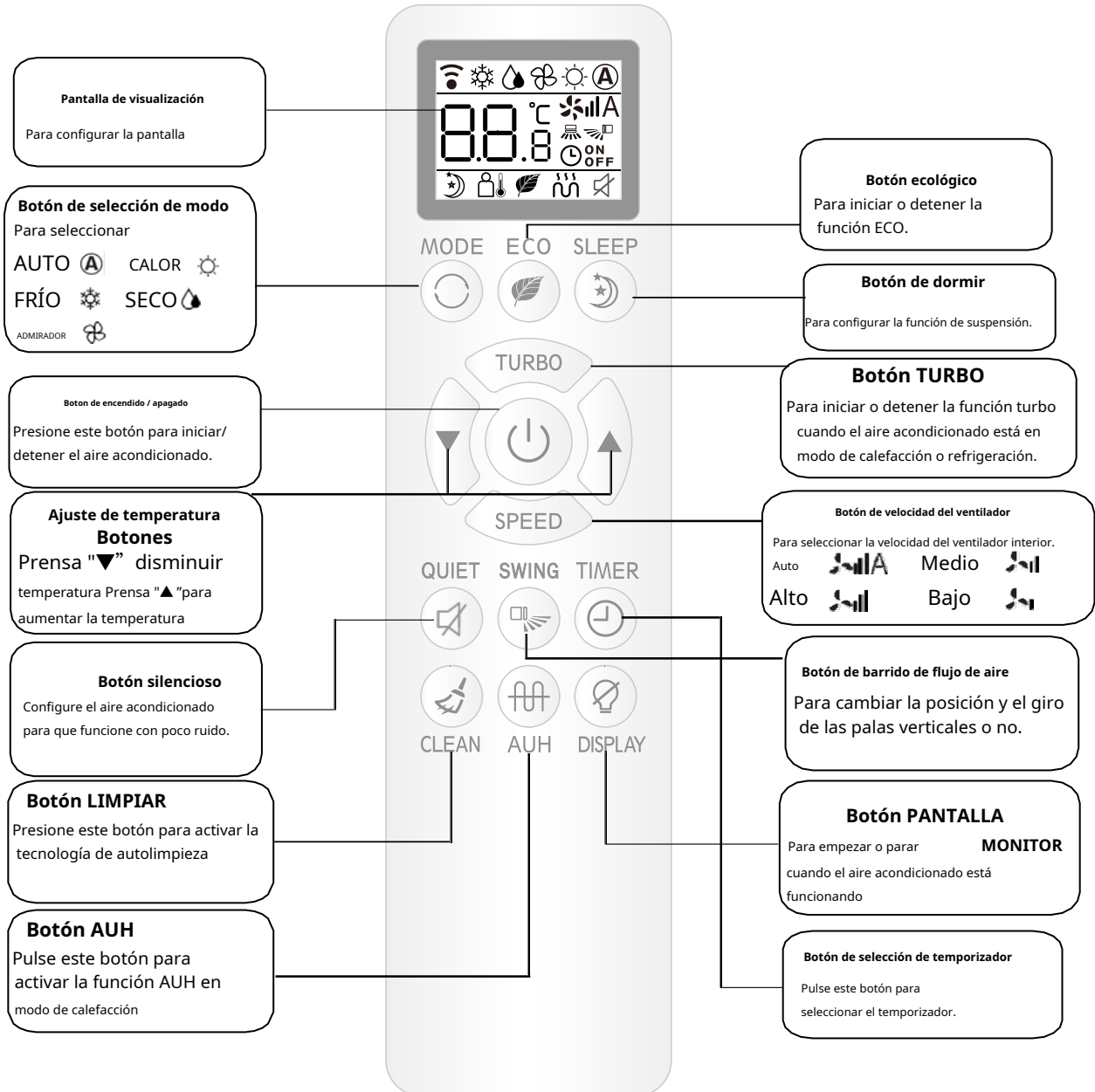

**Observaciones:**

1. La función y la visualización de Calor no están disponibles para acondicionadores de aire solo de refrigeración. .
- 2.CALOR. La función AUTO y la visualización no están disponibles para el acondicionador de aire de tipo solo refrigeración.
3. Si el usuario desea que el aire de la habitación se enfríe o se caliente rápidamente, puede presionar el botón "turbo" en el modo de refrigeración o calefacción, el aire acondicionado funcionará con la función de encendido. Si presiona el botón "turbo" nuevamente, el aire acondicionado saldrá de la función de encendido.
4. La ilustración anterior del control remoto es solo para referencia, puede ser ligeramente diferente del producto real que seleccionó.

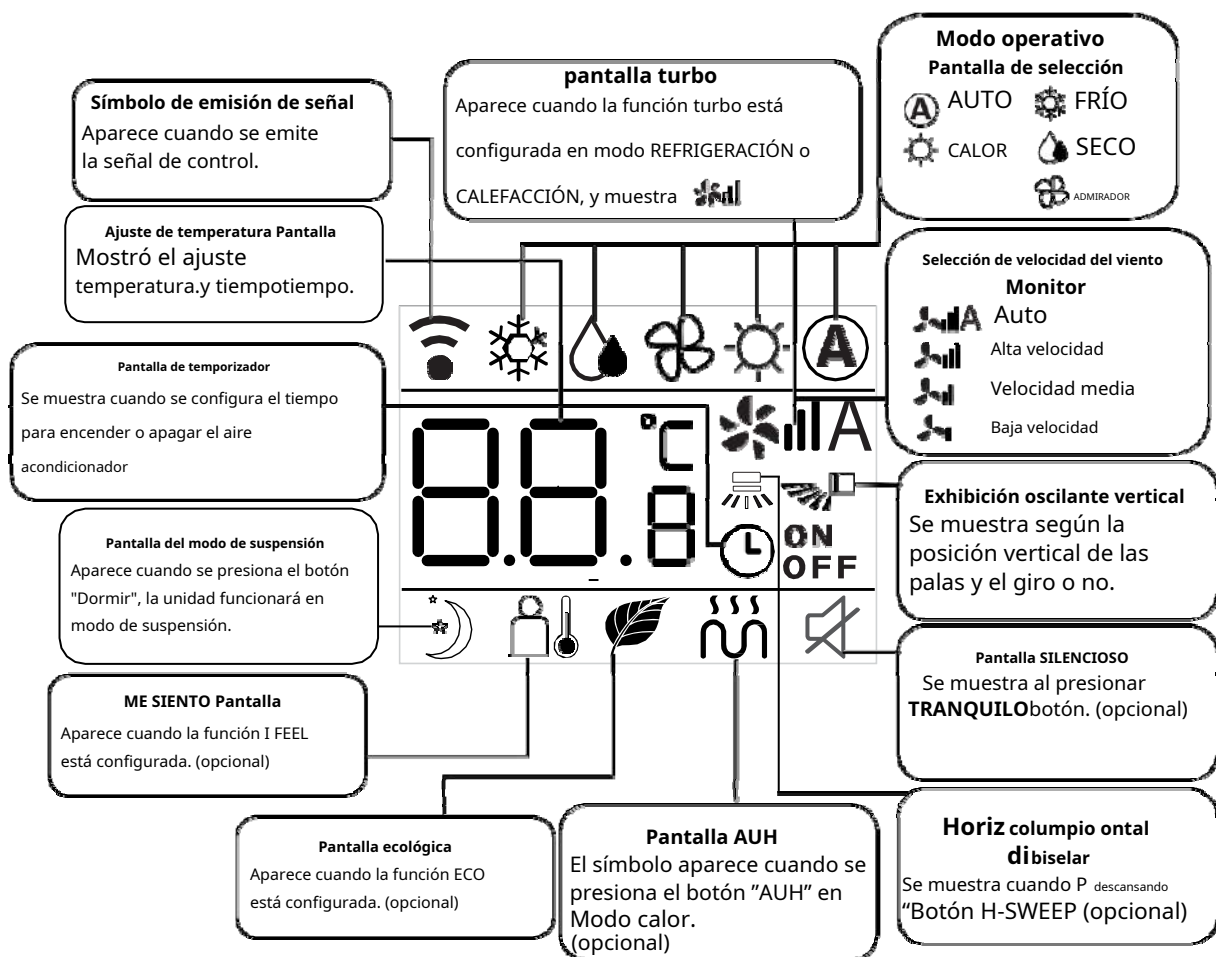

### Instrucciones para el control remoto

- El mando a distancia utiliza dos pilas alcalinas AAA en condiciones normales, las pilas duran unos 6 meses. Utilice dos baterías nuevas de tipo similar (preste atención a los polos durante la instalación).
- Cuando use el control remoto, apunte el emisor de señal hacia el receptor de la unidad interior; No debe haber ningún obstáculo entre el control remoto y la unidad interior.
- Presionar dos botones simultáneamente resultará en una operación incorrecta.
- No utilice equipos inalámbricos (como teléfonos móviles) cerca de la unidad interior. Si se produce una interferencia debido a esto, apague la unidad, desconecte el enchufe, luego vuelva a enchufarlo y enciéndalo después de un rato.
- No hay luz solar directa en el receptor interior, o no puede recibir la señal del control remoto.
- No lances el mando a distancia.
- No coloque el control remoto bajo la luz del sol o cerca del horno.
- No rocíe agua o jugo en el control remoto, use un paño suave para limpiarlo si ocurre. Las baterías deben retirarse del aparato antes de que se desechen y que se eliminen de forma segura.

### 〔Carrera de emergencia〕

Cuando falta el mando a distancia o se agotan las pilas, puede utilizar el botón de emergencia.

#### Método de operación:

En la condición "APAGADO", abra el panel frontal y presione el botón de emergencia con la punta de un bolígrafo o el como y el acondicionador de aire funcionará en el modo "AUTO". Pulse el botón de emergencia de nuevo para apagar la unidad.

### 〔Cómo ajustar el flujo de aire〕

#### Dirección horizontal

Si presiona el botón "H-SWEEP" en el control remoto, las cuchillas de la persiana horizontal no pueden girar. Ajuste el dirección del flujo de aire horizontal a mano. (Figura 1)

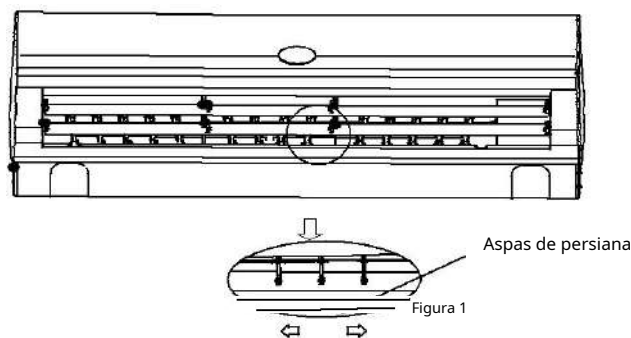

**Advertencia:**  
 Ventilador interior;  
 ¡Mantenga las manos alejadas!

### 〔Operación de suspensión〕

1. Cuando el aire acondicionado esté encendido, presione el botón "SLEEP" para ingresar al modo "SLEEP" y mostrarlo en el control remoto.



2. Presione el botón "SLEEP" nuevamente, desaparecerá en el control remoto y la función de suspensión (ahorro de energía) se cancelará.

#### Nota:

1. Función a: en el modo de suspensión, la temperatura establecida aumentará después de funcionar 1 hora en modo frío y SECO; se reducirá después de funcionar 1 hora en modo calefacción. La temperatura configurada se controlará entre 16°C y 32 °C. Cuando el acondicionador de aire está en modo de suspensión, la velocidad más alta del ventilador interior se establece en nivel medio, pero el usuario puede cambiar la velocidad del ventilador por control remoto.
2. Función b: en el modo de suspensión, la temperatura establecida y la velocidad del ventilador interior no cambiarán, pero la pantalla del aire acondicionado se apagará, excepto por el indicador "RUN".
3. La función a o la función b es opcional y ya está diseñada antes de enviar el producto desde fabricación.

## SERVICIO Y MANTENIMIENTO

El mantenimiento cuidadoso y la revisión por adelantado pueden prolongar la vida útil del acondicionador de aire y ahorrar costos de electricidad.

**Precaución:**

1. Detenga el acondicionador de aire con el control remoto y desconéctelo antes del servicio y mantenimiento.
2. No se pare sobre objetos inestables cuando limpie o dé servicio al aire acondicionado, ya que podría causar lesiones personales.
3. No toque la parte metálica del cuerpo cuando retire el panel frontal, ya que podría causar lesiones personales.



### 〔Limpie el panel frontal y el control remoto〕

Si no se puede eliminar la suciedad, límpiela con un paño húmedo tibio (empapado en agua tibia por debajo de 40°C)

**Precaución:**

1. No limpie la unidad con agua, ya que puede provocar una descarga eléctrica.
2. No limpie el control remoto con agua.
3. No limpie con alcohol, gasolina, aceite de plátano o pulido.
4. No limpie la unidad con violencia, ya que puede causar que el panel frontal se caiga.
5. No limpie el panel frontal ni el control remoto con un cepillo de metal; puede dañar la superficie.



### 〔Filtro de aire limpio〕

1. Abra el panel frontal.(Figura 4)
2. Levante la parte sobresaliente, luego tire de ella hacia abajo y retire el filtro de aire.
3. Límpielo con aspiradora o agua. Si el filtro de aire está muy sucio, límpielo con agua jabonosa tibia o un detergente suave. Luego séquelo a la sombra.
4. Inserte el filtro de aire en la posición anterior y cierre el panel frontal.



Figura 4

**Nota:**

1. El filtro de aire debe limpiarse al menos una vez cada dos semanas, o se reducirá la capacidad de calefacción o refrigeración.
2. No limpie el filtro de aire con un cepillo de metal; puede estar dañado.

〔Sin uso durante mucho tiempo〕

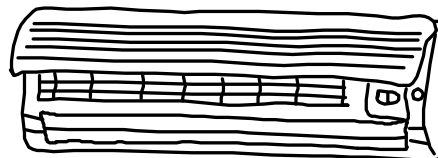
1. Balancee de 3 a 4 horas para secar el aire acondicionado interno.

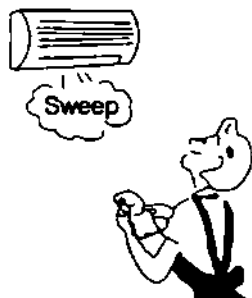

2. Detenga el funcionamiento con el control remoto y luego corte la fuente de alimentación del acondicionador de aire.

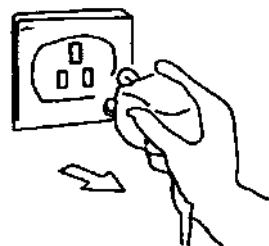

3. Mantenga la red del filtro de aire.

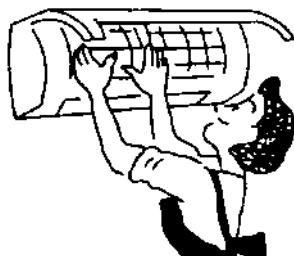

4. Saque las pilas del mando a distancia.

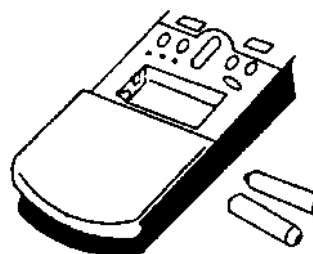

〔Recomendaciones para el Ahorro de Energía〕

**Ajuste de temperatura adecuado**

Es perjudicial para la salud si la habitación está demasiado fría.

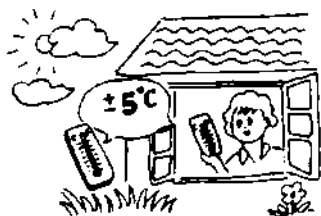

**Evite la luz solar directa**

Cuando se esté enfriando, use una cortina o persiana para obstruir la luz solar directa.

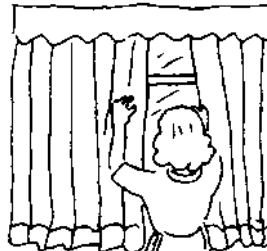

**Evite las fuentes de calor**

Cuando se está enfriando, el uso de otras fuentes de calor puede afectar el efecto de enfriamiento.



**Cerrar puertas y ventanas**

El aire exterior entrante afectará la eficiencia de refrigeración o calefacción.



**Mantenga limpio el filtro de aire**

Mantener limpio el filtro de aire garantiza un funcionamiento de alta eficiencia.

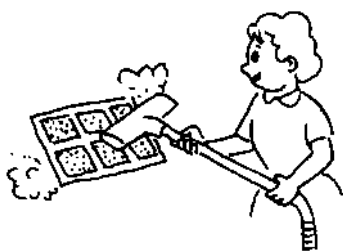

**buena ventilación**

No coloque objetos delante de la entrada y salida de la unidad exterior.

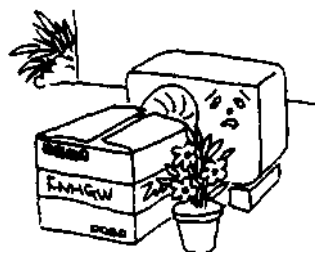

## SOLUCIÓN DE PROBLEMAS

【El aire acondicionado tiene un error】

**Comprobación antes del servicio.**

Fenómeno	Comprobación de artículos
El aire acondicionado hace No operar en absoluto	1. Compruebe si la alimentación está desconectada.
	2. Compruebe si el interruptor está encendido o si el fusible está quemado.
	3. Verifique las baterías del control remoto.
	4. Compruebe si se utilizan equipos de radio dentro de un radio de 1 m alrededor de la unidad.
Pobre Enfriamiento O Rendimiento de calefacción	1. Compruebe si la entrada o salida de aire está bloqueada.
	2. Compruebe si el polvo está bloqueando el filtro.
	3. Puede haber demasiadas personas adentro.
	4. Compruebe si las puertas o ventanas están cerradas.
	5. Compruebe si la velocidad del ventilador o la temperatura establecida no son las adecuadas.

【El control remoto tiene un error】

**La siguiente "solución de problemas" es un fenómeno normal**

Fenómeno	Comprobación de artículos
El ventilador se detiene o la velocidad del ventilador no se puede controlar.	1. Cuando el acondicionador de aire está en modo DRY o SLEEP, a veces no se puede controlar la velocidad del ventilador.
	2. Cuando el acondicionador de aire está en modo FRÍO A PRUEBA DE FLUJO DE AIRE o DESCONGELACIÓN (en modo CALOR), el motor del ventilador se detendrá.
	3. Cuando el acondicionador de aire está en modo FRÍO o SECO, si el acondicionador de aire entra en la operación de prevención de congelamiento, entonces la velocidad del ventilador no se puede controlar.
	4. Cuando el acondicionador de aire está en modo CALOR, si el acondicionador de aire entra en la operación de prevención de sobrecarga de calefacción, entonces no se puede controlar la velocidad del ventilador.



## FENOMENOS NORMALES

Cuando se calienta o se enfría, la sustancia plástica puede emitir un sonido debido al cambio de temperatura.



Si la humedad interior es demasiado alta, se pueden formar gotas de agua en la rejilla frontal de la unidad interior. Este es un fenómeno normal.

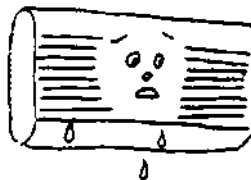

Puede haber un suave sonido de "susurro" cuando la unidad arranca o se detiene. Es el sonido normal del refrigerante que fluye.



Las paredes, las alfombras, los muebles o la ropa en interiores pueden diseminar olores peculiares.



Para proteger la unidad, cuando el compresor se detenga, habrá un retraso de 3 minutos antes de reiniciarse.

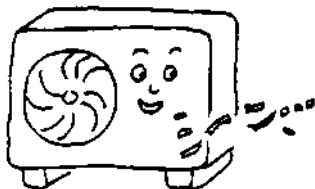

En los primeros minutos de funcionamiento de la calefacción, es posible que no salga viento de la unidad interior.



El agua puede salir de la unidad exterior durante la operación de calefacción.

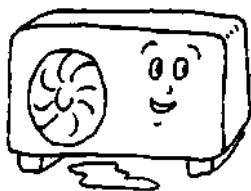

En funcionamiento de calefacción, puede salir vapor cuando se está descongelando.

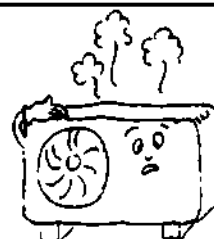

---

# INSTALLATION MANUAL

## 〔Installation Guide〕

- This air conditioner meets the safety and operation standards promulgated by the Nation.
- You need to invite professional air conditioner service and maintenance personnel to install or remove the air conditioner. Problems may occur and you may suffer losses if non- professionals install the air conditioner.
- User shall provide the power that meets installation and operation requirements. please refer to nameplate for details about the voltage for this product. Voltage beyond this scope will affect the normal operation of the air conditioner.
- Separate power point with delay fuse protector or automatic breaker should be used for the air conditioner.
- The air conditioner must be correctly and reliably grounded, or it may cause electric shock or fire.
- Do not switch on the power of the air conditioner before well connecting and carefully checking the tubing and wires.
- The appliance shall not be installed in laundry or bathroom.
- In case necessary, please consult your supply authority for system information.
- The plug shall be accessible after installed the appliance.
- This instruction is subject to change without notice.

## 〔Installation of Accessories〕

- Examine carefully the attached packing list and check whether the accessories are complete.
- Users may need to buy at their own expenses the articles not included in the packing list and may be needed in installing.

## 〔Position for Indoor Unit〕

- Away from the place where there is heat source, steam source, leakage of flammable gas and smoke.
- No obstacles near the inlet and outlet, and keep good ventilation.
- Good discharge for water.
- At least 1m away from wireless equipment (such as TV, radio etc.).
- Mounted on the wall that can bear the weight of the air conditioner and won't produce noise while unit working.

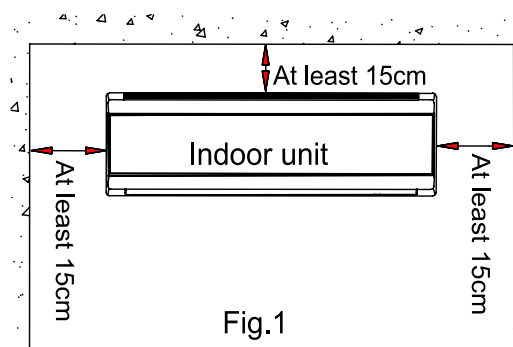

- The distance between the indoor unit and the floor should be greater than 2.3m.
- The plug shall be accessible after installing the appliance.
- Ensure the distance as required in Fig.1.
- The back of the indoor unit should be close to the wall(Fig.1)
- The all figures are only schematic, and they may be slightly different from the actual appliances you selected.

## [[ Position for Outdoor Unit ]]

- Avoid direct sunlight.
- Away from heat source, steam source, leakage of flammable gas, smoke and dust.
- Select a place that is away from rain (snow) and has good ventilation.
- Neighbors will not be affected by the blown wind and noise, or discharged water.
- The place that is easy to install and service.
- Mounted on the solid and reliable foundation will not increase noise or shock.
- To get high cooling performance, make sure the unit's front, rear, left and right sides must be located in an open area.
- The outlet is proposed to be in open air, any obstacle will affect the performances.
- The installing distance must be required as Fig. 2 shows.

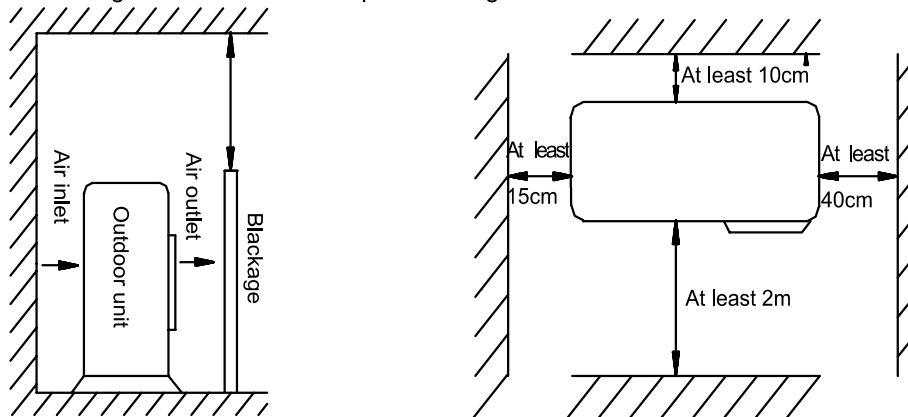

Fig.2

## [[ Tubing Selection ]]

- Ensure that the level (height) difference of indoor and outdoor units and the length of tubing meet the requirement In the Table 1.
- If the tubing is longer than 7m, but shorter than 20m, refrigerant should be supplemented according to Table 1.
- If the installation position of the outdoor unit is higher than indoor unit and the tubing is longer than 10m, added a oil trap on the gas tubing for every 8m. (Fig.3)

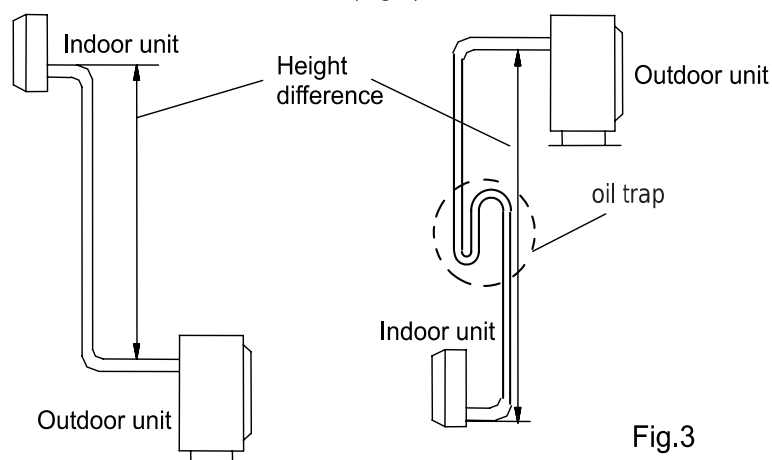

Fig.3

Tabel 1

Tubing size(mm/inch)		Standard tubing Length (m)	Max tubing Length (m)	Height Difference (m)	Additional refrigerants(g/.m)
Liquid tube	Gas tube				
φ 6(1/4")	φ 9.52(3/8")	5.0	9	5	12
φ 6(1/4")	φ 12(1/2")	5.0	12	7	12
φ 6(1/4")	φ 15.88(5/8")	5.0	15	8	12
φ 9.52(3/8")	φ 15.88(5/8")	5.0	15	8	15
φ 9.52(3/8")	φ 19.05(3/4")	5.0	20	10	15

The above dimensions are for reference only, the actual product shall prevail"

### 〔 Fixing Installation Panel 〕

- Dismantle the metal installation board of the indoor unit. Adjust the placa de instalación to horizontal position. La diferencia de altura entre los lados izquierdo y derecho de la instalación. El tablero debe tener menos de 5 mm. ( Fig. 4 )
- Drill holes and insert plastic expansion tubes at the appropriate locations on the wall and fix the installation board on the wall with M5x30 screws . Ensure that there must be at least 4 fixed points in the wall. Ensure installation board to horizontal position.
- Drill holes as Fig.5 shows. The hole, 80mm in diameter, should slightly slide down outwards..
- Cut PVC tubes at a slight angle in the length shorter than wall thickness and inset it into the hole.( Fig.5 )
- Mount the wall cap.

left side right side

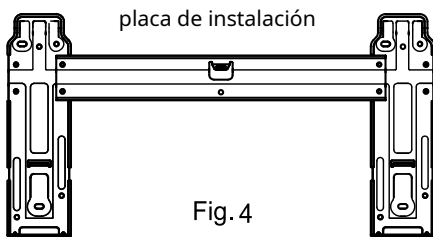

Fig. 4

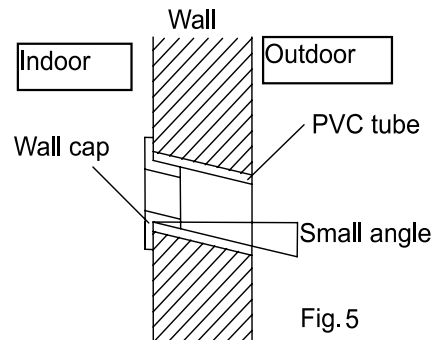

Fig. 5

left side right side

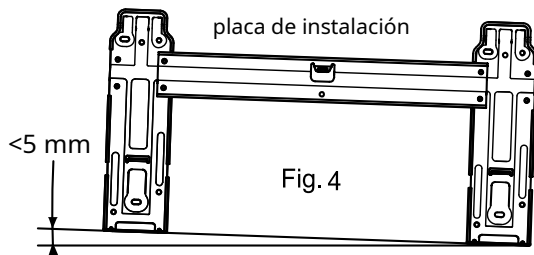

Fig. 4

horizontal direction

left side right side

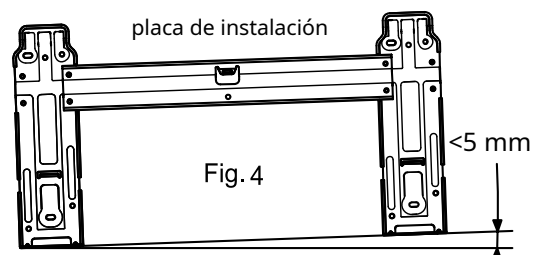
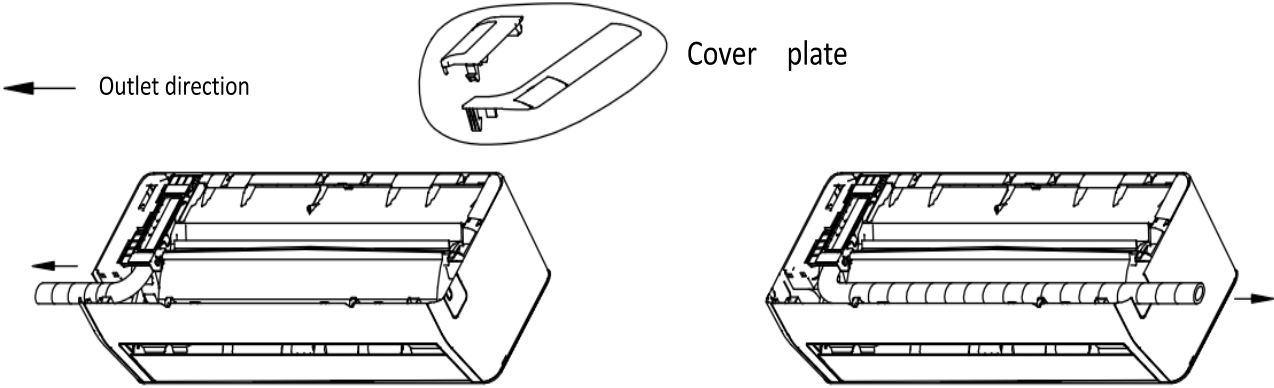

Fig. 4

horizontal direction

# Attachment: installation instructions for decorative cover plate



PASO 1: Envuelva con cinta protectora de PVC la tubería de drenaje, la tubería de cobre y el cable.  
Ajuste el tubo de tubo de cobre a una forma adecuada.

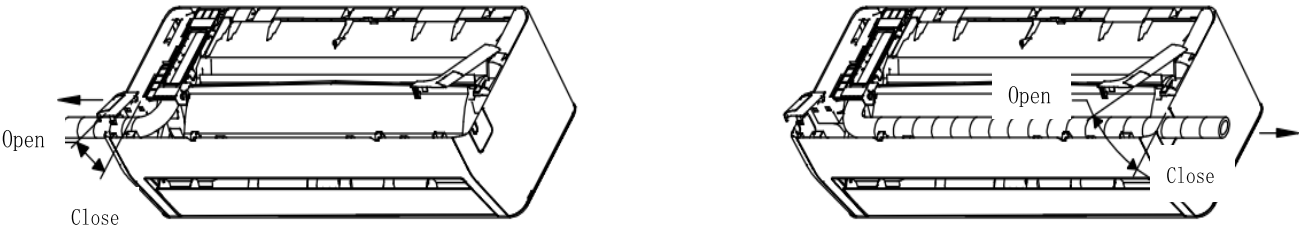

STEP 2: Install the cover plate



## 〔Indoor Unit Installation〕

The tube may be connected in several directions as below shown Figures.

1. Connecting right back tube (similar to right lower tube) (Optional, Refer to Fig.6)

- Pull out the tubing from bottom of the chassis; and connect the drainpipe. Strap the joint of tubing reliably.
- Lead the connecting wire to the indoor unit (Do not connect to the power).
- Strap together the tubes, discharge pipe and connecting wire with adhesive tape. The discharge pipe is put at the below.
- Remove the board which is on the chassis.
- Check if the connections are reliable.
- Mount the indoor unit on the two hooks at the upper part of installation board. (refer to Fig.8)

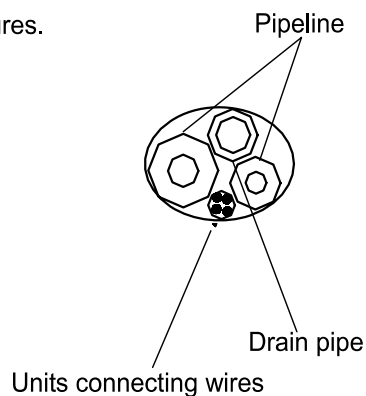

Fig.6

2. Connecting left back tube (similar to left lower tube). (Optional, Refer to Fig9)

- Move the discharge tube to the left side, and discharge cap to the right side.
- Fix the tubes in the slot of the indoor unit with the fix clamp.
- The following mounting steps are the same as those in “1. Connecting right back tube.”

Notes: Left chart is available for the position of drain hose, refer to Fig.7.

Right chart is available for the position of drain hose, refer to Fig.9.

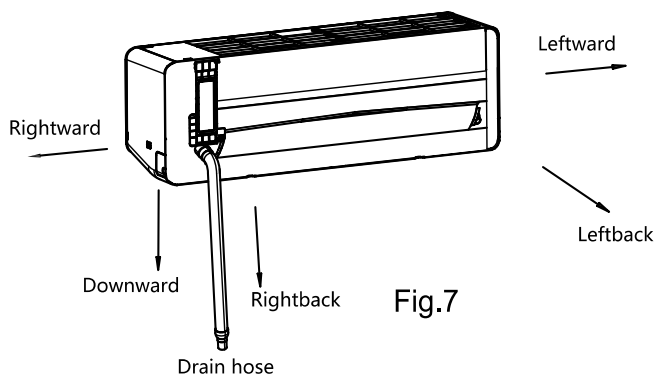

Fig.7

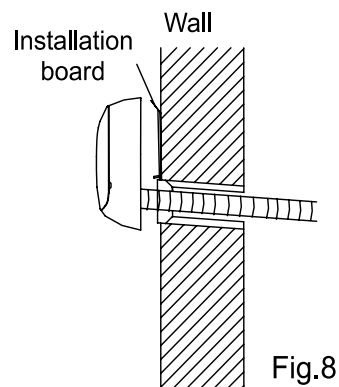

Fig.8

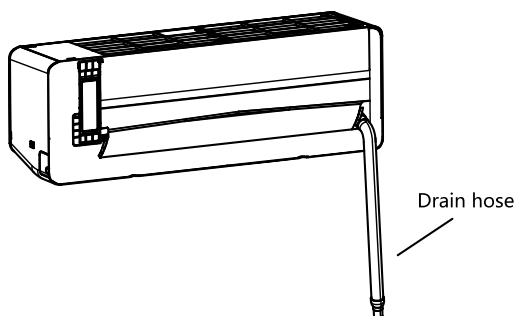
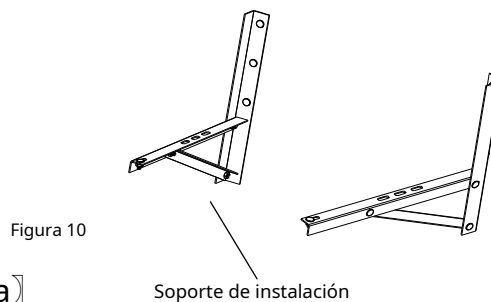

Fig.9

## 【Instalación de la unidad exterior】

- Si se necesitan soportes de instalación para instalar la unidad exterior, el usuario puede comprar los soportes de nuestra empresa o agentes(Figura 10) .
- Ensamble el marco de montaje y los soportes con los 6 tornillos, arandelas planas, arandelas elásticas y tuercas adjuntos.
- Taladre 6 o más agujeros en la pared de acuerdo con el tamaño de los pies del acondicionador de aire. Determine las ubicaciones para montar los soportes izquierdo y derecho. Asegúrese de que los soportes izquierdo y derecho estén al mismo nivel.
- Fije el marco de instalación en la pared con pernos expansivos. Fije la unidad exterior con 4 pernos en los soportes de instalación.
- Los accesorios deben estar bien atornillados; La conexión debe ser firme y confiable.
- Al instalar la unidad exterior, el cuerpo debe colgarse con cuerdas para evitar que se caiga. Durante la instalación o reparación, se debe evitar que las herramientas y los componentes se caigan. Verifique regularmente la confiabilidad del marco de instalación.



## 【Conexión de tubería】

- Retire la tapa de la válvula de la unidad exterior.
- Alinee la tuerca abocinada con el centro de la rosca y atorníllela firmemente con la mano.
- Apriete firmemente la tuerca abocinada con una llave dinamométrica hasta que la llave dinamométrica produzca un sonido de "clic". Se recomienda utilizar una llave dinamométrica para conectar la tubería. Si se utiliza otra llave flexible o fija, puede dañar la boca de la bocina debido a una fuerza inadecuada.
- El ángulo de flexión del tubo no debe ser demasiado pequeño o el tubo puede romperse, por lo que el personal de servicio debe usar un doblador de tubos para doblar el tubo.
- Nunca permita que entre agua, polvo o arena en la tubería.

**Tabla 2**

Tamaño de la tubería (mm/pulgada)	Esfuerzo de torsión (N.m)
6 (1/4")	15~20
9,52 (3/8")	35~40
12(1/2")	50~55
15,88 (5/8")	60~75
19,05 (3/4")	80~95

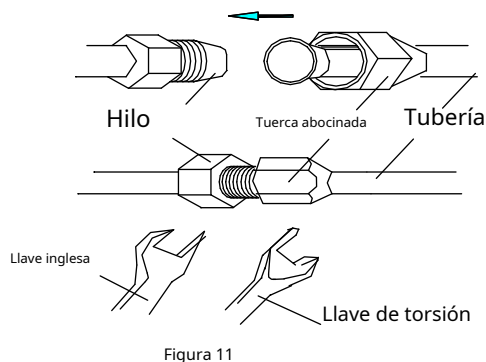

## 〔Conexión de cables〕

### 1. Unidad interior

- Abra hacia arriba la rejilla de entrada al máximo.
- Retire la cubierta eléctrica de la unidad.
- Afloje el tornillo en la tapa de conexión. (Fig.12)
- Desmonte la placa de presión de alambre.
- Conecte los cables de conexión de alimentación y el cable de control de señal por separado a los terminales correspondientes. (En la figura 14, elija el mismo diagrama de cableado solo con el diagrama de cableado de la unidad). Afloje el tornillo en la placa de tierra; presione firmemente el cable de tierra.
- Presione firmemente los cables de conexión de la unidad con la placa de presión de cables conductores.
- Cierre la tapa de conexión, atornillela firmemente y cierre la rejilla de entrada.



Figura 12

### 2. Unidad exterior

- Desenrosque y desmonte la tapa del dispositivo electrónico (Fig.13).
- Desmonte la placa de presión del sujetador de alambre.
- Conecte los cables de conexión de la unidad por separado a los terminales correspondientes. (Fig. 14)
- Presione firmemente los cables de conexión de la unidad con la placa de presión superior.
- Vuelva a montar la tapa del dispositivo electrónico en su posición original.

Si el usuario desea prolongar o reemplazar el cable de alimentación, hágalo de acuerdo con la mesa (Tabla3).

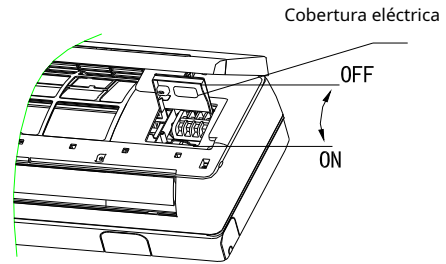

Figura 13

Tabla 3

		Energía conectando alambres	Señal control cable	Cable de alimentación
	máx. Longitud	10m	10m	5m
5K/7K/9K/12K	Cruz área en corte	$\geq 1,0 \text{ mm}^2$	$\geq 1,0 \text{ mm}^2$	$\geq 1,0 \text{ mm}^2$
16K/18K		$\geq 1,5 \text{ mm}^2$	$\geq 1,5 \text{ mm}^2$	$\geq 1,5 \text{ mm}^2$
18K/21K/24K/28K		$\geq 2,5 \text{ mm}^2$	$\geq 0,75 \text{ mm}^2$	$\geq 2,5 \text{ mm}^2$

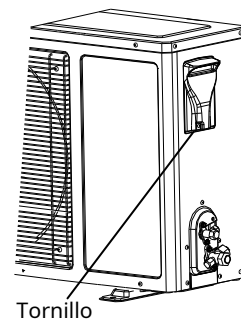

① Diagrama de conexión para 7K,9K,12K,18K,24K.



Figura 14

---

## Notes:

- Earthing screw must use special screw(stainless machining screws or copper screws M4)
- Ensure that all wires are securely connected, will not loose or separate.
- Ensure that wire connections are carried out according to the wiring diagram of the air conditioner.
- The above figures are only schematic, and they may be slightly different from the actual appliances you select.

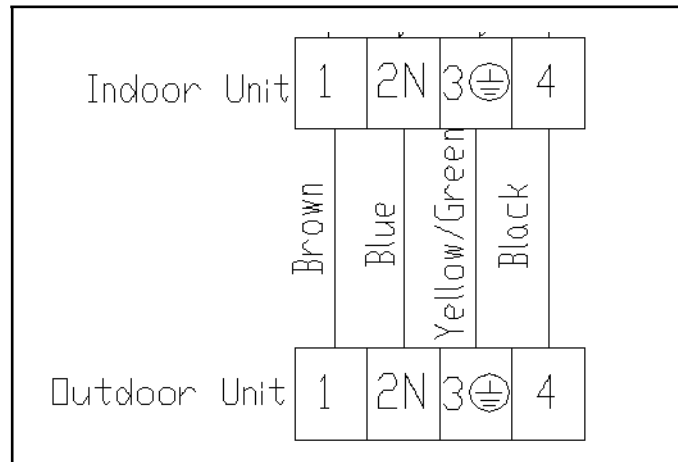
## Tube Strapping

- Strapping with PVC Protective tape must be careful, do not damage the pipeline and drain pipe.
- Strapping should start from the lower part of the outdoor unit to the indoor unit.
- Fix the PVC tape with adhesive tape to prevent loosing.
- Drainpipe should slightly slide down outwards to ensure drainage well.
- When the indoor unit is lower than the outdoor unit, bend the tube to proper extent to prevent water draining into house.
- Fix the tube bundle with tube clamps on the wall.
- Allow enough space between discharge pipe and the ground. Do not put the discharge pipe in water or ditch.
- Seal the external wall holes with sealing gum or putty.

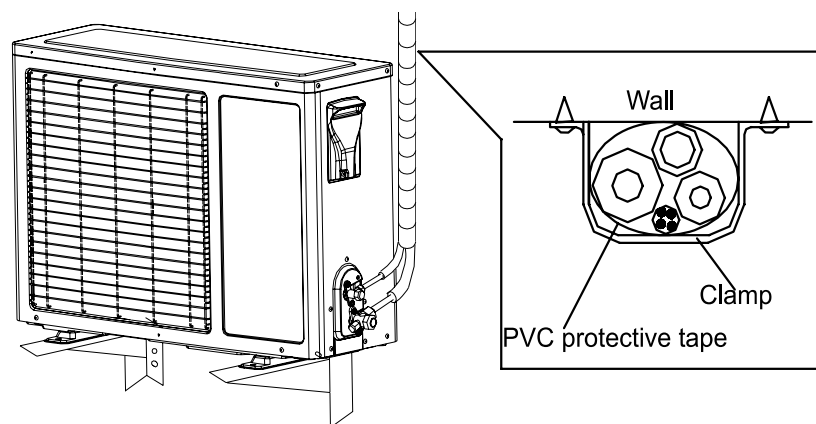
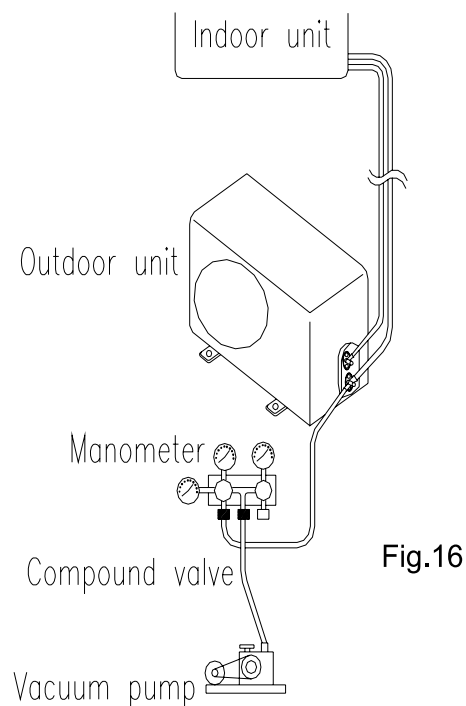

Fig.15

---

## Pumping type

- Make sure that all the tubes of indoor and outdoor unit are connecting well.
- Take off valve bonnet from two-way and three-way valves by spanner; connect vacuum pump and compound valve to the service valve bonnet.
- Open the low-pressure switch of compound valve, and run vacuum pump until units' internal pressure at 10 mmHg.
- After pump vacuum, close the low-pressure switch of compound valve, and then close vacuum pump. Turn anti-clockwise 90° Spool of narrow pipe service valve by hexagon spanner, tightly with clockwise turning after stopping for 10 seconds.
- Check with soap water or leak detector whether there is leakage at all connections of indoor and outdoor unit.
- Open wide and narrow pipe service valves by hexagon spanner for running.
- Take off the connection pipeline of wide pipe service valve.
- Screw tightly the entire valve bonnet by torque spanner.
- Check with soap water or leak detector whether there are leakage at all indoor and outdoors' connections.
- Put the valve bonnet and lid back to position.



---

## [ Drainage ]

### 1. No need drainage treatment

In regions where become cold in the winter, don't install the drain elbow joint to prevent drain water from freezing and causing the fan to be damaged. This drainage treatment is not necessary for cooling-only type air conditioner.

### 2. When need drainage treatment

- Please use drain elbow joint (in accessory bag). Outdoor unit should be placed on blocks.

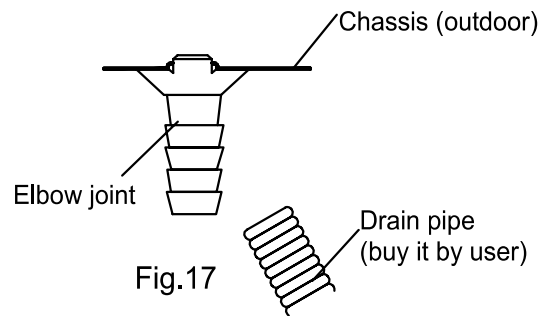

Installation for the cover of valve:

For the whole unit that individual cover of valve is available (refer to packing list), the installing method is as follow:

After connecting the connection pipes between indoor and outdoor units followed by the installing method mentioned above, take out the cover of valve from the accessory bag, and fix it on the side of outdoor unit with three corresponding screws ( inside the accessory bag ).

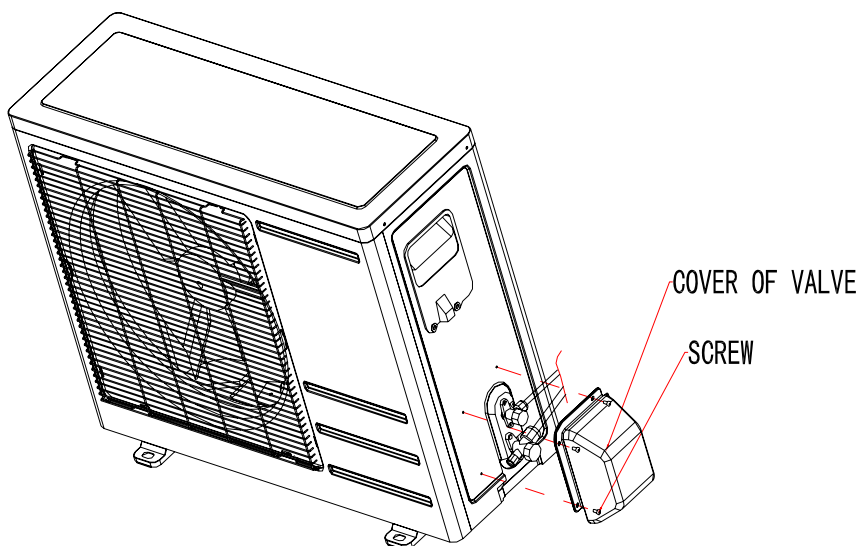

Fig.18

## SICHERHEITSVORKEHRUNGEN



**WARNUNG: Das Befolgen dieser grundlegenden Vorsichtsmaßnahmen reduziert die Gefahr von Feuer, elektrischem Schlag, Verletzungen oder Tod, wenn Sie Ihre Druckluft verwenden Klimaanlage.**

1. Die Klimaanlage muss an die richtige Steckdose oder den richtigen Trennschalter angeschlossen werden Stromversorgung. Und nur die angegebene Leistung kann verwendet werden.

2. Eine ordnungsgemäße Erdung muss gewährleistet sein, um die Stromschlag- und Brandgefahr zu verringern

**UNTERLASSEN SIESCHNEIDEN ODER ENTFERNEN SIE DEN ERDUNGSSTIFT.** Wenn Sie keinen dreipoligen haben Steckdose oder Unterbrecher in der Wand, lassen Sie diese von einem zertifizierten Elektriker installieren Steckdose oder Unterbrecher. Die Wandsteckdose oder der Unterbrecher MUSS ordnungsgemäß geerdet sein.

3. **UNTERLASSEN SIE** verwenden, wenn das Netzkabel ausgefranst oder anderweitig beschädigt ist. Vermeiden Sie es auch, es zu verwenden, wenn es welche gibt Risse oder Abriebschäden entlang der Länge, des Steckers oder Steckers.

4. **UNTERLASSEN SIE** VERWENDEN SIE EINEN ADAPTER ODER EIN VERLÄNGERUNGSKABEL.

5. **UNTERLASSEN SIE** Blockieren Sie den Luftstrom innerhalb oder außerhalb der Klimaanlage mit Jalousien, Vorhängen, Schutzvorrichtungen Abdeckungen, Sträucher oder Rouge.

6. Achten Sie auf scharfe Kanten an den vorderen und hinteren Rippen des Geräts, die Schnittverletzungen verursachen könnten schwere Verletzung.

7. Seien Sie vorsichtig, wenn Sie die Klimaanlage anheben, um die Einheit zu installieren oder zu entfernen. Verwenden Sie immer zwei oder mehr Leute dafür.

8. Unterbrechen Sie immer die Stromversorgung der Klimaanlage, bevor Sie sie warten oder bewegen.

9. Bei manchen Geräten gibt es aus diesem Grund keinen passenden Stecker für das Netzkabel Strom, Unter dieser Bedingung sollte ein geeigneter Leistungsschalter mit dem Netzkabel verbunden werden, Daher ist der Anweisungsteil für die Verwendung von Steckern für diese Typen nicht verfügbar.

# INHALT

## 1. SICHERHEITSHINWEISE

Symbol Beschreibung.....	2
Installationsanleitung.....	2
Bedienungsanleitung.....	3
Sicherheitshinweise.....	6

## 2. PRODUKTEINFÜHRUNG

Schutzfunktionen.....	7
-----------------------	---

## 3. BESCHREIBUNG DER KOMPONENTEN

Geräteansicht.....	8
Anzeigebildschirm.....	9
Fernbedienung.....	10
Anzeige der Fernbedienung.....	11

## 4. SERVICE UND WARTUNG

Frontblende und Fernbedienung reinigen.....	13
Luftfilter reinigen.....	13
Lange Zeit nicht verwendet.....	14
Empfehlungen zum Energiesparen.....	15

## 5. FEHLERBEHEBUNG

Klimaanlage ist fehlerhaft.....	16
Fernbedienung ist fehlerhaft.....	16

## 6. NORMALE PHÄNOMENE.....

17

# SICHERHEITSHINWEISE

## 〔Symbolbeschreibung〕



### **Warnung:**

Ein Symbol, das auf einen Betrieb hinweist, der zu Personenschäden oder schweren Schäden führen kann.



### **Vorsicht:**

Ein Symbol, das auf einen Betrieb hinweist, der zu Personen- oder Sachschäden führen kann.

## 〔Installationsanweisung〕



### **Warnung**

#### **— Installieren Sie niemals selbst.**

Eine Split-Klimaanlage wird für eine lange Zeit für Sie arbeiten, wenn sie richtig installiert ist. Eine unsachgemäße Installation kann zu Problemen wie Wasser- oder Kältemittellecks, Stromschlägen oder Bränden führen.



### **Vorsicht**

#### **Bitte bestätigen Sie Folgendes vor der Installation**

##### **— Leistungsspezifikationen**

Stellen Sie sicher, dass die Kapazität der Steckdose oder des Trennschalters und des Netzkabels ausreichend ist, die Spannung korrekt ist und die Steckdose oder der Trennschalter geerdet ist. Andernfalls besteht Brand- oder Stromschlaggefahr.

##### **— Korrekte Verbindung von Drähten und Rohren**

Ein unsachgemäßer Anschluss kann die Effizienz verringern oder dazu führen, dass die Klimaanlage nicht mehr läuft. Wasser- oder Kältemittellecks können ebenfalls die Folge sein.

##### **— Installationsumgebungen**

Installieren Sie die Klimaanlage nicht an Orten, an denen brennbare oder ätzende Luft vorhanden ist.

##### **— Gebrauchsanweisung**

Bitte betreiben Sie die Klimaanlage gemäß dieser Anleitung.

## 〔Gebrauchsanweisung〕

### WARNUNGEN

Es ist sehr wichtig, die Sicherheitshinweise zu befolgen. Diese Nachrichten können Sie davor bewahren, verletzt oder getötet zu werden. Warnsymbole mahnen zur Vorsicht und bedeuten Gefahr. Befolgen Sie immer die Anweisungen, um sicher zu gehen und das Risiko zu verringern Verletzung oder Tod. Warn- und Gefahrenzeichen werden Sicherheitshinweisen vorangestellt.

#### Elektrische Sicherheit

**Erdung:** Dieses Raumklimagerät muss geerdet werden.



Die Erdung reduziert das Risiko eines Stromschlags, indem ein Fluchtdraht für die bereitgestellt wird elektrischer Strom.

Wenn das Netzkabel einen Erdungsstecker mit Erdungskabel hat, stecken Sie es in eine Steckdose die ordnungsgemäß installiert und geerdet ist.

Wenn das Netzkabel keinen Erdungsstecker mit Erdungskabel hat, muss das Erdungskabel mit dem ordnungsgemäß installierten und geerdeten Unterbrecher verbunden werden.

**Warnung:** Die unsachgemäße Verwendung des Erdungssteckers oder Unterbrechers kann zu Stromschlaggefahr führen.

Wenden Sie sich an einen qualifizierten Elektriker, wenn Sie die Erdungsanweisungen nicht verstehen oder wenn Sie sich nicht sicher sind, ob die Klimaanlage ordnungsgemäß geerdet ist. Wenn die Wandsteckdose oder der Trennschalter nicht geerdet sind, wenden Sie sich bitte an einen Elektriker, um sie durch eine ordnungsgemäß geerdete Steckdose oder einen ordnungsgemäß geerdeten Trennschalter ersetzen zu lassen.

**Schneiden oder entfernen Sie unter keinen Umständen den dritten (Erdungs-) Stift des Netzkabels.**

**Adapterstecker: Wir raten dringend davon ab, einen Adapterstecker oder Unterbrecher zu verwenden.**

#### Betriebsbedingungen

1. Temperatur: T1-Instanz:  $-7^{\circ}\text{C}\sim 43^{\circ}\text{C}$  ( $16^{\circ}\text{C}\sim 43^{\circ}\text{C}$  nur Kühltyp)

T3-Instanz:  $-7^{\circ}\text{C}\sim 52^{\circ}\text{C}$  ( $16^{\circ}\text{C}\sim 52^{\circ}\text{C}$  nur Kühltyp)

Wenn das Gerät längere Zeit über der Temperatur läuft, kann dies dazu führen, dass die Kühlleistung abnimmt oder der Schutz funktioniert.

2. Relative Luftfeuchtigkeit:  $< 80\%$

Wenn das Gerät außerhalb des Feuchtigkeitsbereichs läuft, kann sich in der Nähe des Flügels und des Auslasses der Klimaanlage Kondenswasser bilden. Es ist normal.

3. Im Heizbetrieb kann ein seltsamer Geruch aus dem Gerät austreten. Es ist ein normales Phänomen.

4. Die Leistungsparameter beziehen sich auf das Typenschild.

5. Die Wasserdichtigkeit des Innengeräts ist IPX0. Verwenden Sie es nicht in der Wäsche oder im Badezimmer.

6. Das Außengerät kann nicht in einem geschlossenen Bereich installiert werden.

7. Sicherung: T3.15AL250V, Nennstrom: 3,15 A.



### Tipps

- Installieren Sie das Gerät auf der Nordseite, da dies normalerweise die Schattenseite ist. Dadurch wird der Betrieb Ihres Geräts verbessert.
- Verwenden Sie die richtige elektrische Spannung und die richtige Amperezahl, damit das Gerät effektiv läuft.
- Lassen Sie Änderungen an Ihrer Steckdose oder Ihrem Trennschalter nur von einem zertifizierten Elektriker vornehmen.
- Verwenden Sie eine eigene Leitung für den Betrieb Ihrer Klimaanlage, um die Möglichkeit einer elektrischen Überspannung zu vermeiden.
- Wenn das Netzkabel beschädigt ist, muss es vom Hersteller oder seinem Kundendienst oder einer ähnlich qualifizierten Person ersetzt werden, um Gefahren zu vermeiden.
- Die Abmessungen des Raums, der für die ordnungsgemäße Installation des Geräts erforderlich ist, einschließlich der zulässigen Mindestabstände zu angrenzenden Strukturen.
- Das Gerät muss gemäß den nationalen Verdrahtungsvorschriften installiert werden.
- Trennen Sie die Stromversorgung vor der Reinigung und Wartung.
- Wenn das Gerät nicht per Stecker angeschlossen ist, Eine allpolige Trennvorrichtung mit mindestens 3 mm Trennungsabstand in allen Polen und ein Fehlerstromschutzschalter (RCD) mit einer Nennleistung von über 10 mA müssen gemäß den nationalen Vorschriften in die feste Verkabelung eingebaut werden.
- Wenn das Gerät per Stecker angeschlossen ist, er muss so positioniert werden, dass der Stecker zugänglich ist.

### Leitfaden zum Energiesparen

- Achten Sie bei der Installation Ihrer Klimaanlage darauf, alle Bereiche abzudichten, in denen die Möglichkeit eines Luftaustritts besteht.
- Der Luftstrom sollte drinnen weder durch Vorhänge, Vorhänge oder Möbel noch draußen durch Sträucher oder Sträucher blockiert werden.
- Verwenden Sie nicht unnötig elektrisches Licht oder andere Geräte, die Wärme erzeugen. Lassen Sie die Jalousien und Vorhänge an allen anderen Fenstern zugezogen.
- Verwenden Sie beim Kochen einen Abluftventilator in der Küche, um die erzeugte überschüssige Wärme abzuführen.

〔Gebrauchsanweisung〕

Es darf nur einphasiger Wechselstrom verwendet werden.  
Einzelheiten entnehmen Sie bitte dem Typenschild.

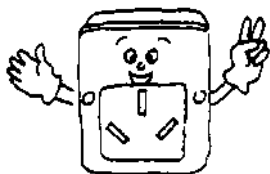

Verwenden Sie das angegebene Netzkabel; ändern Sie es nicht.

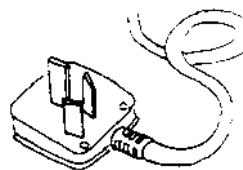

Stecken Sie keine Finger oder Stöcke in den Einlass oder Auslass der Klimaanlage; der laufende Ventilator kann Verletzungen verursachen.

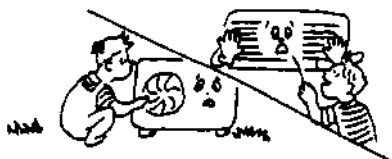

Stellen Sie nichts auf das Außengerät.



Schalten Sie das Gerät nicht ein oder aus, indem Sie den Stecker einstecken oder herausziehen oder den Trennschalter ein- oder ausschalten.



Halten Sie die Innenräume belüftet, insbesondere wenn Gasgeräte in Betrieb sind.



Ersetzen Sie die Sicherung nicht durch Bleidraht oder andere Materialien.



Ziehen Sie den Netzstecker oder schalten Sie den Unterbrecher aus, wenn die Klimaanlage längere Zeit nicht benutzt wird.

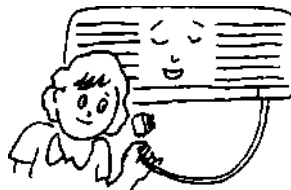

[Sicherheitsanleitung]



**Warnung:** Das Gerät ist nicht für den unbeaufsichtigten Gebrauch durch kleine Kinder oder gebrechliche Personen bestimmt. Kleine Kinder sollten beaufsichtigt werden, um sicherzustellen, dass sie nicht mit dem Gerät spielen. Wenn das Netzkabel beschädigt ist, muss es vom Hersteller oder seinem Kundendienst oder einer ähnlich qualifizierten Person ersetzt werden, um Gefahren zu vermeiden.

Schließen Sie die Erdungsleitung nicht an Gas- oder Wasserleitungen an. Unsachgemäße Erdung kann zu Stromschlägen führen.



Ziehen Sie nicht den Netzstecker und schalten Sie den Trennschalter nicht aus, wenn er in Betrieb ist.



Schalten Sie das Gerät aus; Trennen Sie die Stromquelle und wenden Sie sich an den Kundendienst, wenn ein ungewöhnliches Phänomen auftritt (z. B. Brandgeruch).



Installieren Sie die Klimaanlage nicht an Orten, an denen brennbare Gase austreten können.



Stellen Sie keine Pflanzen oder Tiere direkt in den Luftstrom der Klimaanlage. Dies könnte ihnen schaden.



Bitte wenden Sie sich für den Service an einen Kundendienstmitarbeiter. Unsachgemäßer Service kann zu Unfällen führen.



Schalten Sie das Gerät aus, trennen Sie die Stromquelle und vergewissern Sie sich, dass der Lüfter stoppt, bevor Sie das Gerät reinigen.

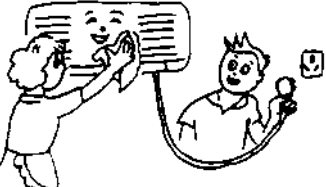

Für den Aus- und Einbau der Klimaanlage wenden Sie sich bitte an Fachleute oder wenden Sie sich an den Kundendienst.

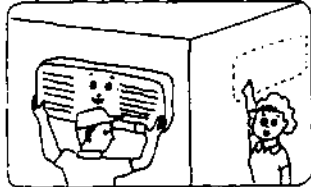

---

# PRODUKTEINFÜHRUNG

## 〔Funktionen schützen〕

Protect-Funktionen können die Lebensdauer der Klimaanlage verlängern und für einen angenehmeren Luftstrom sorgen.

### **Anlaufverzögerungsschutz für den Kompressor**

Der Kompressor arbeitet mindestens 3 Minuten (5 Minuten im Heizmodus) nach dem Abschalten wieder, um den Druckausgleich des Kühltanks aufrechtzuerhalten.

**Bemerkungen:** Nachdem das Gerät zum ersten Mal mit Strom versorgt wurde, hat der Kompressor 1 Minute Zeit, um zu arbeiten.

### **Abtauen (nicht verfügbar für Klimaanlagen vom Typ „Nur Kühlen“)**

Bei niedriger Außentemperatur und hoher Luftfeuchtigkeit kann der Außenwärmetauscher vereisen. In diesem Fall hat die automatische Enteisung 3~10 Minuten lang funktioniert. Pausenanzeige leuchtet, Innen- und Außenlüfter stoppen.

### **Heizungsüberlastschutz (nicht verfügbar für nur kühlende Klimaanlagen)**

Wenn die Temperatur des Innenrohrs zu hoch ist, tritt die Klimaanlage in den Heizungsüberlastschutz ein. Und die Geschwindigkeit des Innenventilators sollte automatisch auf einen höheren Gang eingestellt werden. Außenventilator und Kompressor können gestoppt werden. Wenn die Innenrohrtemperatur auf einen Nennwert fällt, verlässt die Klimaanlage den Heizungsüberlastschutz. Der Lüftermotor des Innengeräts kehrt in den normalen Zustand zurück.

### **Funktion zum Ausblasen der Restwärme (nicht verfügbar für Klimaanlagen vom Typ „Nur Kühlen“)**

Der Innenlüfter läuft 80 Sekunden lang mit niedriger Lüftergeschwindigkeit weiter, wenn die Klimaanlage im Heizmodus gestoppt wird.

### **Kühlluftströmungssicher (nicht verfügbar für Klimaanlagen vom Typ „Nur Kühlen“)**

In den ersten paar Minuten des Heizbetriebs leuchtet die PAUSE-Anzeige; Der Innenventilator läuft nicht und die Lamellen können nicht gesteuert werden. Etwa 5 Minuten später bläst die Klimaanlage einen warmen Luftstrom, die PAUSE-Anzeige ist aus.

### **Frostschutz**

Um zu verhindern, dass der Innenwärmetauscher im Kühl- und Entfeuchtungsbetrieb einfriert, können der Kompressor oder der Außenlüfter aufhören zu laufen; Die Geschwindigkeit des Innenventilators wird automatisch auf einen höheren Gang eingestellt.

### **Trocken zur Enzymprävention (Optional)**

Der Lüftermotor des Innengeräts läuft 3 Minuten lang mit niedriger Lüftergeschwindigkeit weiter, wenn er im Kühlmodus ausgeschaltet wird, um einen trockenen Zustand im Inneren des Geräts zu gewährleisten.

### **Stromversorgung zurücksetzen oder automatisch neu starten (alternativ)**

Stromversorgung zurücksetzen: Bei einer Stromunterbrechung schaltet sich die Klimaanlage automatisch aus. Wenn der Strom wiederhergestellt ist, wird das Gerät automatisch zurückgesetzt. Zur Energieeinsparung bleibt die Klimaanlage im PAUSE-Status, wenn sich keine Person im Raum befindet. Der Benutzer muss die Klimaanlage per Fernbedienung einschalten.

Automatischer Neustart: Das Gerät speichert den Betriebsmodus, die Luftstromeinstellung, die Temperatureinstellung usw., sodass bei einem Stromausfall während des Betriebs automatisch die gleichen Betriebsbedingungen wiederhergestellt werden, wenn die Stromversorgung wiederhergestellt wird.

### **Kühlüberlastfunktion (optional)**

Wenn im Kühlbetrieb die Temperatur des Außenwärmetauschers zu hoch ist, wird die Drehzahl des Innenventilators automatisch auf einen niedrigeren Gang eingestellt und der Kompressor kann gestoppt werden.

**Tropfwassergeschützt (optional)**

Im Kühl- und Entfeuchtungsbetrieb können Lamellen die Position automatisch ändern tropfen verhindern.

## BESCHREIBUNG DER KOMPONENTEN

〔Ansicht der Einheit〕

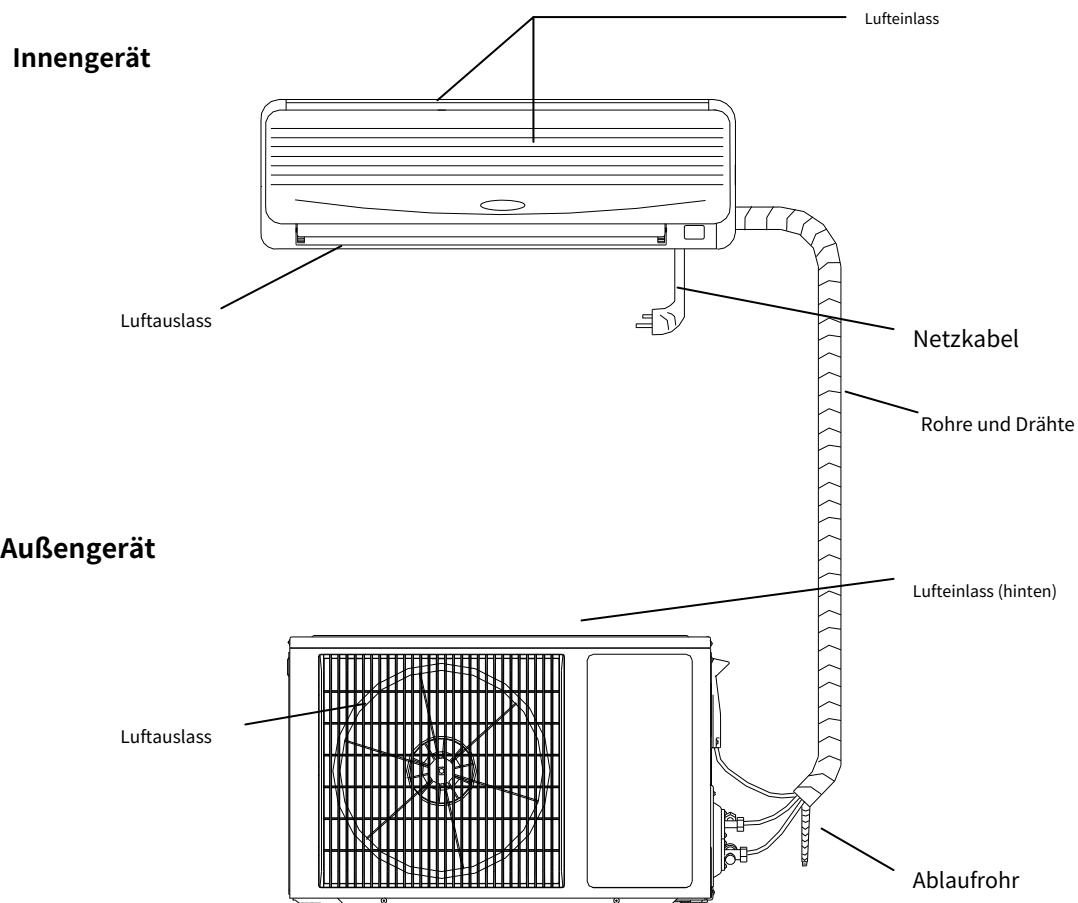

**Bemerkungen:**

Die Klimaanlage besteht aus Inneneinheit, Außeneinheit und Fernbedienung. Das Design und die Form sind für verschiedene Modelle unterschiedlich. Die obigen Abbildungen sind nur schematisch und können geringfügig von den von Ihnen ausgewählten Geräten abweichen.

## 〔Display screen〕



**Gesundheitsindikator** Diese Leuchte leuchtet, wenn die UV-C-Funktion oder der Kaltplasma-Generator in Betrieb sind.



**Timer-Anzeige** : This signal light is on when the unit is in Timer.



**Kompressoranzeige** : This signal light is on when the compressor is running



**WIFI-Anzeige**: Blinken im Namen der Suche, Beleuchtung im Namen der abgeschlossenen WIFI-Verbindung, was bedeutet, dass die WIFI-Funktion Betrieb und Anwendung sein kann. (Weitere Einzelheiten finden Sie in der WIFI-Bedienungsanleitung)"

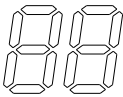

**Temperaturanzeige** : This display can show the set temperature .when the indicator display F4,F1orF2, means the air conditioner runs abnormally

(The above LED display is for reference only, subject to the actual product)

【Fernbedienung】

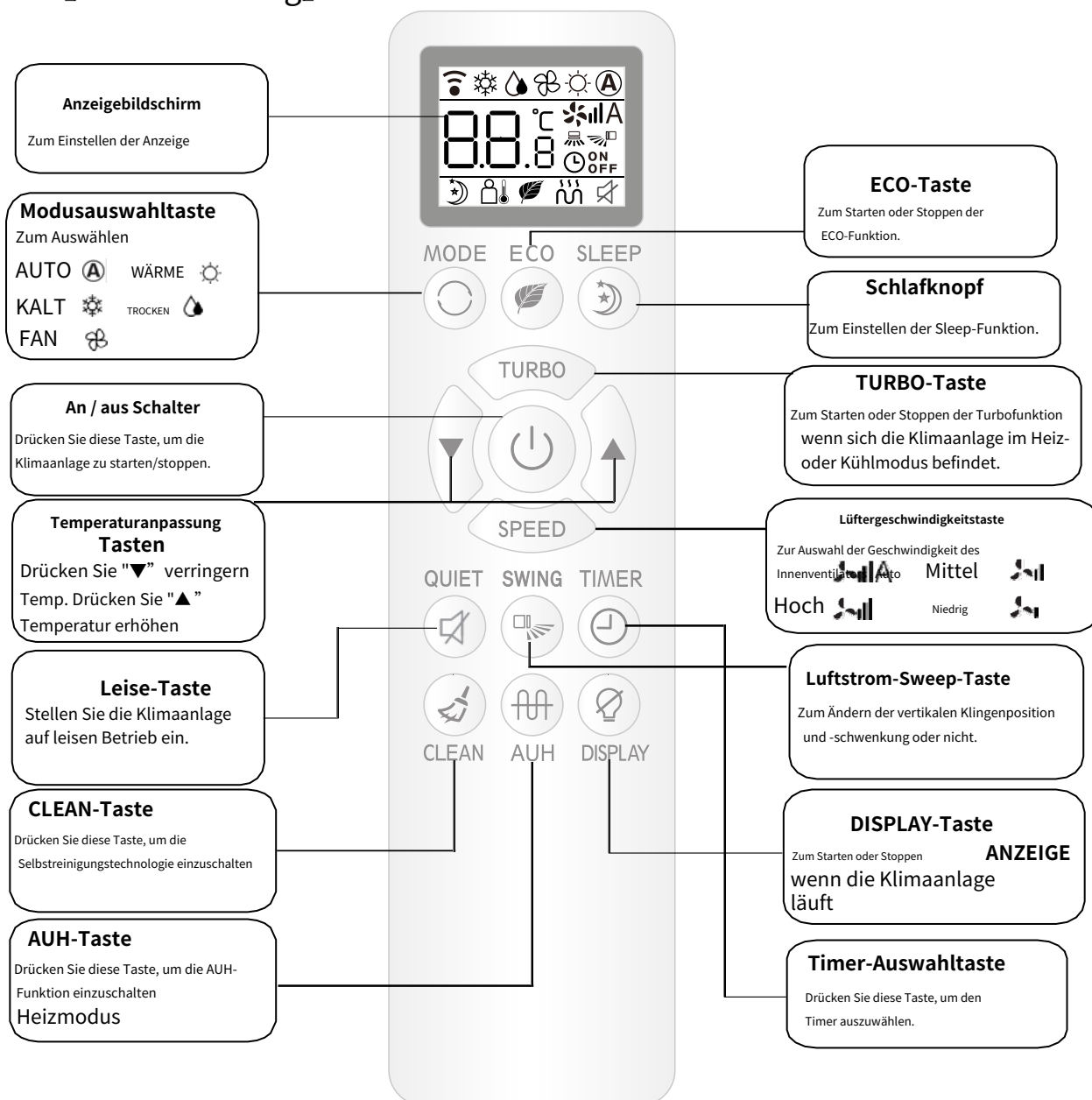

**Bemerkungen:**

1. Die Funktion und Anzeige von Heat ist nicht verfügbar für Klimaanlage, die nur kühlen. .
2. WÄRME- Die AUTO-Funktion und -Anzeige sind für Klimaanlage vom Typ „Nur Kühlen“ nicht verfügbar.
3. Wenn der Benutzer die Raumluft schnell abkühlen oder erwärmen möchte, kann der Benutzer im Kühl- oder Heizmodus die „Turbo“-Taste drücken, die Klimaanlage läuft in der Power-Funktion. Wenn die „Turbo“-Taste erneut gedrückt wird, verlässt die Klimaanlage die Power-Funktion.
4. Die obige Abbildung der Fernbedienung dient nur als Referenz und kann geringfügig von dem tatsächlich ausgewählten Produkt abweichen.

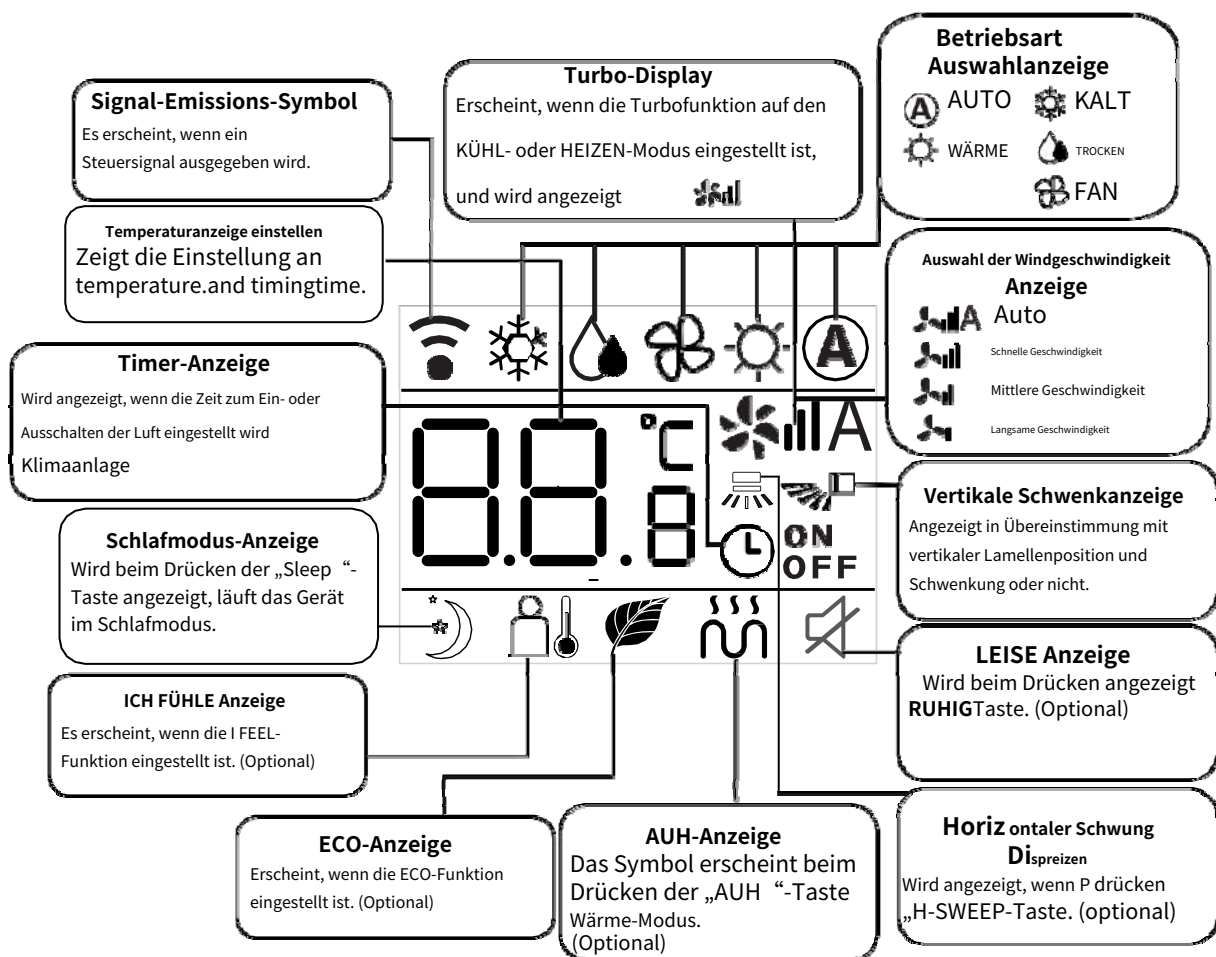

## Anleitung für Fernbedienung

- Die Fernbedienung verwendet unter normalen Bedingungen zwei AAA-Alkalibatterien, die Batterien halten etwa 6 Monate. Bitte verwenden Sie zwei neue Batterien gleichen Typs (Polung beim Einbau beachten).
- Richten Sie bei Verwendung der Fernbedienung den Signalsender auf den Empfänger des Innengeräts; Zwischen der Fernbedienung und dem Innengerät darf kein Hindernis sein.
- Das gleichzeitige Drücken von zwei Tasten führt zu einer Fehlbedienung.
- Verwenden Sie keine drahtlosen Geräte (wie Mobiltelefone) in der Nähe des Innengeräts. Treten dadurch Störungen auf, schalten Sie bitte das Gerät aus, ziehen Sie den Netzstecker, stecken Sie ihn wieder ein und schalten Sie ihn nach einer Weile wieder ein.
- Der Innenempfänger ist nicht direktem Sonnenlicht ausgesetzt, oder er kann das Signal von der Fernbedienung nicht empfangen.
- Gießen Sie die Fernbedienung nicht.
- Legen Sie die Fernbedienung nicht ins Sonnenlicht oder in die Nähe des Ofens.
- Sprühen Sie kein Wasser oder Saft auf die Fernbedienung, verwenden Sie zur Reinigung ein weiches Tuch, falls dies auftritt. Die Batterien müssen vor der Verschrottung aus dem Gerät entfernt und sicher entsorgt werden.



## 〔Notlauf〕

Wenn die Fernbedienung fehlt oder die Batterien leer sind, können Sie die Notruftaste verwenden.

### **Betriebsmethode:**

Öffnen Sie im „AUS“-Zustand die Frontplatte und drücken Sie die Notruftaste mit der Spitze eines Kugelschreibers oder des Stiftes, wie und die Klimaanlage arbeitet im „AUTO“-Modus. Drücken Sie die Notruftaste erneut, um das Gerät auszuschalten.

## 〔So stellen Sie den Luftstrom ein〕

### **Horizontale Richtung**

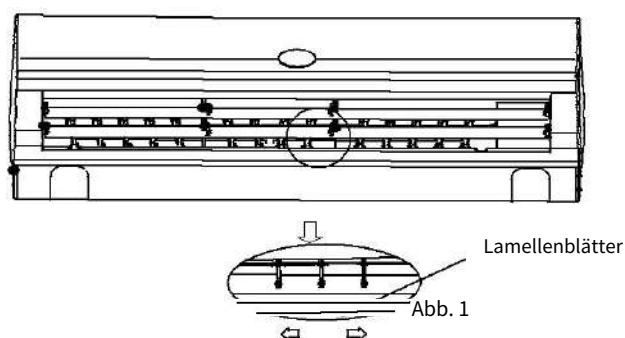

Wenn Sie „H-SWEEP“ auf der Fernbedienung drücken, können die horizontalen Lamellen nicht schwingen und die horizontale Luftstromrichtung von Hand. (Abb. 1)



### **Warnung:**

Lüfter innen;  
Finger weg!

## 〔Schlafbetrieb〕

1. Wenn die Klimaanlage eingeschaltet ist, drücken Sie die „SLEEP“-Taste, um in den „SLEEP“-Modus zu gelangen und  Wille auf der Fernbedienung anzuzeigen.
2. Drücken Sie die „SLEEP“-Taste erneut , wird auf der Fernbedienung ausgeblendet und die Schlaffunktion (Energiesparfunktion) wird abgebrochen.

### **Notiz:**

1. Funktion a: Im Schlafmodus wird die eingestellte Temperatur erhöht, nachdem sie 1 Stunde im Kühl- und DRY-Modus gelaufen ist; sie wird nach 1 Stunde Betrieb im Heizmodus verringert. Die eingestellte Temperatur wird zwischen 16°C und 32°C. Wenn sich die Klimaanlage im Schlafmodus befindet, ist die höchste Lüftergeschwindigkeit des Innengeräts eingestellt mittlere Stufe, aber der Benutzer kann die Lüftergeschwindigkeit per Fernbedienung ändern.
2. Funktion b: Im Schlafmodus ändern sich die eingestellte Temperatur und die Geschwindigkeit des Innenventilators nicht, aber der Anzeigebildschirm der Klimaanlage schaltet sich mit Ausnahme der „RUN“-Anzeige aus.
3. Funktion a oder Funktion b ist optional und wird bereits vor dem Versand des Produkts entworfen Manufaktur.

## SERVICE UND WARTUNG

Eine sorgfältige Wartung und Überholung im Vorfeld kann die Lebensdauer der Klimaanlage verlängern und Stromkosten sparen.

### Vorsicht:

1. Stoppen Sie die Klimaanlage über die Fernbedienung und ziehen Sie den Stecker ab, bevor Sie Service- und Wartungsarbeiten durchführen.
2. Stellen Sie sich nicht auf instabile Gegenstände, wenn Sie die Klimaanlage reinigen oder warten, da dies zu Verletzungen führen kann.
3. Berühren Sie nicht das Metallteil des Gehäuses, wenn Sie die Frontplatte entfernen, da dies zu Verletzungen führen kann.



### 〔Reinigen Sie die Frontblende und die Fernbedienung〕

Wenn der Schmutz nicht entfernt werden kann, reinigen Sie ihn bitte mit einem warmen, feuchten Tuch (getränkt mit warmem Wasser unter 40°C)

### Vorsicht:

1. Reinigen Sie das Gerät nicht mit Wasser, da dies zu Stromschlägen führen kann.
2. Reinigen Sie die Fernbedienung nicht mit Wasser.
3. Nicht mit Alkohol, Benzin, Bananenöl oder Poliermitteln reinigen.
4. Reinigen Sie das Gerät nicht mit Gewalt, da dies dazu führen kann, dass die Frontplatte herunterfällt.
5. Reinigen Sie die Frontplatte oder die Fernbedienung nicht mit einer Metallbürste; es kann die Oberfläche beschädigen.



### 〔Luftfilter reinigen〕

1. Öffnen Sie die Frontblende. (Abb.4)
2. Heben Sie den vorstehenden Teil an, ziehen Sie ihn dann nach unten und entfernen Sie den Luftfilter.
3. Reinigen Sie es mit einem Staubsauger oder Wasser. Wenn der Luftfilter stark verschmutzt ist, reinigen Sie ihn bitte mit warmem Seifenwasser oder einem milden Reinigungsmittel. Dann im Schatten trocknen.
4. Setzen Sie den Luftfilter in die vorherige Position ein und schließen Sie die Frontplatte.



Abb. 4

### Notiz:

1. Der Luftfilter sollte mindestens alle zwei Wochen gereinigt werden, da sonst die Heiz- oder Kühlleistung reduziert wird.
2. Reinigen Sie den Luftfilter nicht mit einer Metallbürste; es kann beschädigt werden.

【Keine Verwendung für lange Zeit】

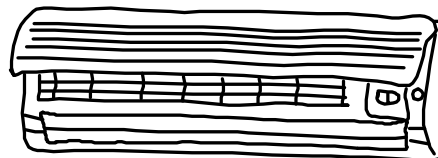
1. Schwenken Sie 3-4 Stunden, um die interne Klimaanlage zu trocknen.

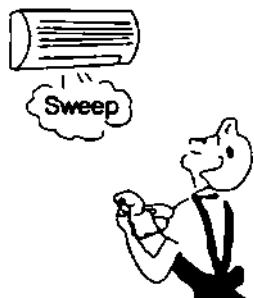

2. Stoppen Sie den Betrieb über die Fernbedienung und unterbrechen Sie dann die Stromquelle der Klimaanlage.

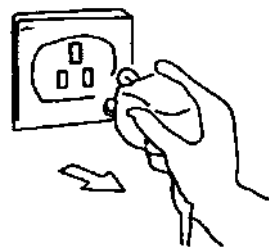

3. Luftfilternetz warten.

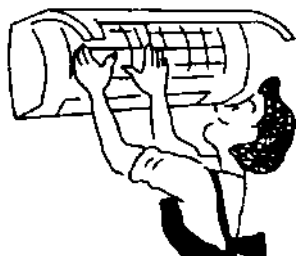

4. Nehmen Sie die Batterien aus der Fernbedienung heraus.

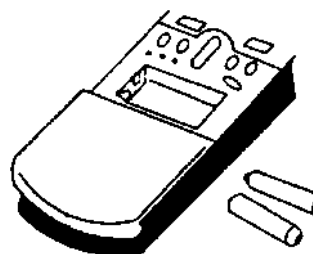

## 〔Empfehlungen zum Energiesparen〕

### Geeignete Temperatureinstellung

Es ist gesundheitsschädlich, wenn der Raum zu kalt ist.

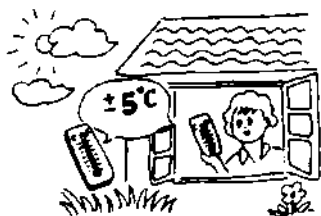

### Vermeide direktes Sonnenlicht

Wenn es abkühlt, verwenden Sie bitte einen Vorhang oder eine Jalousie, um direktes Sonnenlicht zu blockieren.

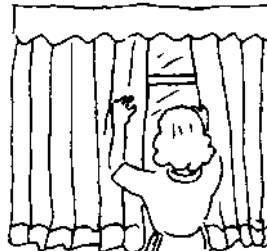

### Vermeiden Sie Wärmequellen

Wenn es kühlt, kann die Verwendung anderer Wärmequellen die Kühlwirkung beeinträchtigen.



### Schließen Sie Türen und Fenster

Einströmende Außenluft beeinträchtigt die Kühl- oder Heizeffizienz.



### Halten Sie den Luftfilter sauber

Das Sauberhalten des Luftfilters gewährleistet einen hocheffizienten Betrieb.

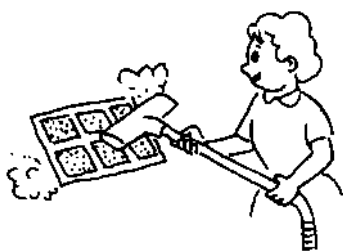

### Gute Belüftung

Stellen Sie keine Gegenstände vor den Einlass und Auslass des Außengeräts.

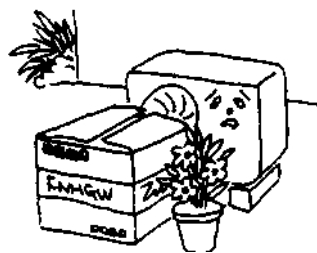

## FEHLERBEHEBUNG

〔Die Klimaanlage ist fehlerhaft〕

**Überprüfung vor dem Service.**

Phänomen	Überprüfung von Artikeln
Klimaanlage tut es Überhaupt nicht operieren	1. Prüfen Sie, ob die Stromversorgung unterbrochen ist.
	2. Prüfen Sie, ob der Trennschalter eingeschaltet oder die Sicherung durchgebrannt ist.
	3. Überprüfen Sie die Batterien der Fernbedienung.
	4. Prüfen Sie, ob im Umkreis von 1 m um das Gerät Funkgeräte verwendet werden.
Arm Kühlung oder Heizleistung	1. Prüfen Sie, ob der Lufteinlass oder -auslass blockiert ist.
	2. Prüfen Sie, ob Staub den Filter verstopft.
	3. Möglicherweise befinden sich zu viele Personen im Haus.
	4. Prüfen Sie, ob Türen oder Fenster geschlossen sind.
	5. Prüfen Sie, ob die Lüftergeschwindigkeit oder die eingestellte Temperatur nicht stimmen.

〔Die Fernbedienung hat einen Fehler〕

**Die folgende „Fehlersuche“ ist ein normales Phänomen**

Phänomen	Überprüfung von Artikeln
Lüfter stoppt oder Lüftergeschwindigkeit kann nicht gesteuert werden.	1. Wenn sich die Klimaanlage im DRY- oder SLEEP-Modus befindet, kann die Lüftergeschwindigkeit manchmal nicht gesteuert werden.
	2. Wenn sich die Klimaanlage im KÜHLLUFTSTROMSICHERT- oder DEFROSTING-Betrieb (im HEIZEN-Modus) befindet, stoppt der Lüftermotor.
	3. Wenn sich die Klimaanlage im COOL- oder DRY-Modus befindet und die Klimaanlage in den Frostschutzbetrieb wechselt, kann die Lüftergeschwindigkeit nicht gesteuert werden.
	4. Wenn sich die Klimaanlage im HEIZEN-Modus befindet und die Klimaanlage in den Heizüberlastungsschutzmodus wechselt, kann die Lüftergeschwindigkeit nicht gesteuert werden.

## NORMALE PHÄNOMENE

Beim Erhitzen oder Abkühlen kann Kunststoff aufgrund der Temperaturänderung ein Geräusch von sich geben.



**ich** Wenn die Luftfeuchtigkeit im Innenraum zu hoch ist, können sich Wassertropfen auf dem Frontgitter des Innengeräts bilden. Dies ist ein normales Phänomen.

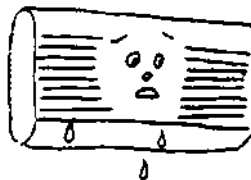

Beim Starten oder Stoppen des Geräts kann ein leises „Rascheln“ zu hören sein. Es ist das normale Geräusch von fließendem Kältemittel.



Wände, Teppiche, Möbel oder Kleidung in Innenräumen können eigenartige Gerüche verbreiten.



Um das Gerät zu schützen, gibt es beim Stoppen des Kompressors eine 3-minütige Verzögerung vor dem Neustart.

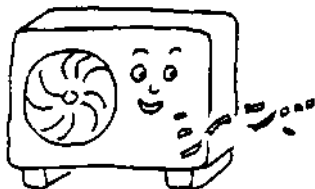

In den ersten paar Minuten des Heizbetriebs kommt möglicherweise kein Wind aus dem Innengerät.



Während des Heizbetriebs kann Wasser aus der Außeneinheit fließen.

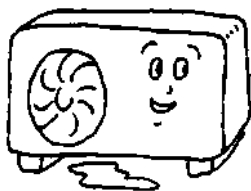

Im Heizbetrieb kann beim Abtauen Dampf austreten.

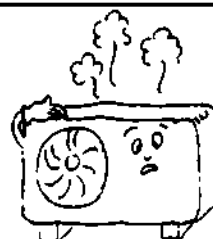

---

# INSTALLATION MANUAL

## 〔Installation Guide〕

- This air conditioner meets the safety and operation standards promulgated by the Nation.
- You need to invite professional air conditioner service and maintenance personnel to install or remove the air conditioner. Problems may occur and you may suffer losses if non-professionals install the air conditioner.
- User shall provide the power that meets installation and operation requirements. please refer to nameplate for details about the voltage for this product. Voltage beyond this scope will affect the normal operation of the air conditioner.
- Separate power point with delay fuse protector or automatic breaker should be used for the air conditioner.
- The air conditioner must be correctly and reliably grounded, or it may cause electric shock or fire.
- Do not switch on the power of the air conditioner before well connecting and carefully checking the tubing and wires.
- The appliance shall not be installed in laundry or bathroom.
- In case necessary, please consult your supply authority for system information.
- The plug shall be accessible after installed the appliance.
- This instruction is subject to change without notice.

## 〔Installation of Accessories〕

- Examine carefully the attached packing list and check whether the accessories are complete.
- Users may need to buy at their own expenses the articles not included in the packing list and may be needed in installing.

## 〔Position for Indoor Unit〕

- Away from the place where there is heat source, steam source, leakage of flammable gas and smoke.
- No obstacles near the inlet and outlet, and keep good ventilation.
- Good discharge for water.
- At least 1m away from wireless equipment (such as TV, radio etc.).
- Mounted on the wall that can bear the weight of the air conditioner and won't produce noise while unit working.

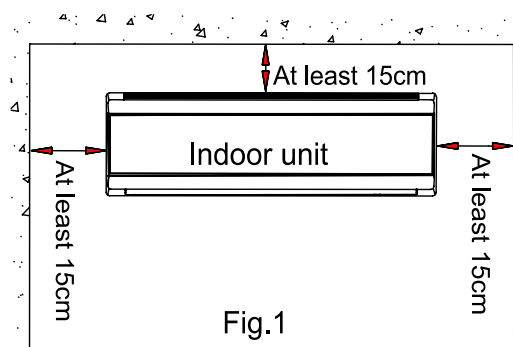

- The distance between the indoor unit and the floor should be greater than 2.3m.
- The plug shall be accessible after installing the appliance.
- Ensure the distance as required in Fig.1.
- The back of the indoor unit should be close to the wall(Fig.1)
- The all figures are only schematic, and they may be slightly different from the actual appliances you selected.

## [[ Position for Outdoor Unit ]]

- Avoid direct sunlight.
- Away from heat source, steam source, leakage of flammable gas, smoke and dust.
- Select a place that is away from rain (snow) and has good ventilation.
- Neighbors will not be affected by the blown wind and noise, or discharged water.
- The place that is easy to install and service.
- Mounted on the solid and reliable foundation will not increase noise or shock.
- To get high cooling performance, make sure the unit's front, rear, left and right sides must be located in an open area.
- The outlet is proposed to be in open air, any obstacle will affect the performances.
- The installing distance must be required as Fig. 2 shows.

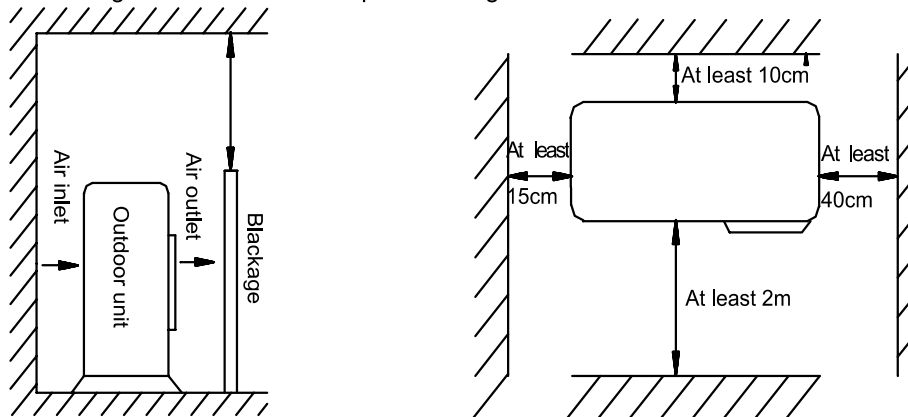

Fig.2

## [[ Tubing Selection ]]

- Ensure that the level (height) difference of indoor and outdoor units and the length of tubing meet the requirement in the Table 1.
- If the tubing is longer than 7m, but shorter than 20m, refrigerant should be supplemented according to Table 1.
- If the installation position of the outdoor unit is higher than indoor unit and the tubing is longer than 10m, add an oil trap on the gas tubing for every 8m. (Fig.3)

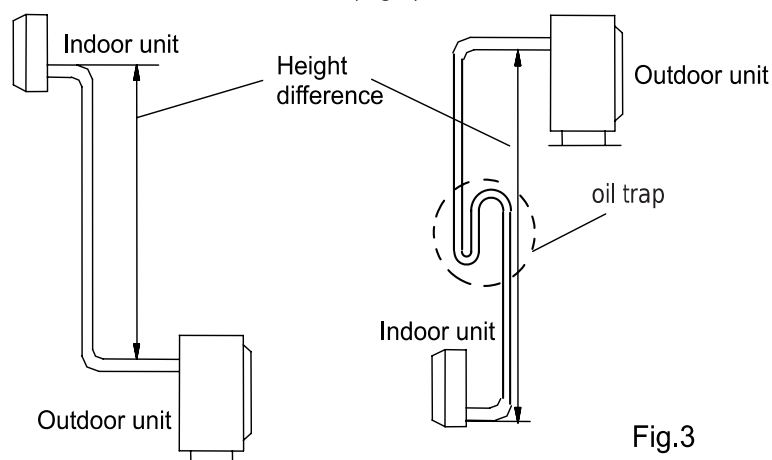

Fig.3



Tabel 1

Tubing size(mm/inch)		Standard tubing Length (m)	Max tubing Length (m)	Height Difference (m)	Additional refrigerants(g/.m)
Liquid tube	Gas tube				
φ 6(1/4")	φ 9.52(3/8")	5.0	9	5	12
φ 6(1/4")	φ 12(1/2")	5.0	12	7	12
φ 6(1/4")	φ 15.88(5/8")	5.0	15	8	12
φ 9.52(3/8")	φ 15.88(5/8")	5.0	15	8	15
φ 9.52(3/8")	φ 19.05(3/4")	5.0	20	10	15

The above dimensions are for reference only, the actual product shall prevail"

### 〔 Fixing Installation Panel 〕

- Dismantle the metal installation board of the indoor unit. Adjust the Installationsplatine to horizontal position. Der Höhenunterschied zwischen der linken und rechten Seite der Installation Brett sollte weniger als 5 mm betragen. ( Fig. 4 )
- Drill holes and insert plastic expansion tubes at the appropriate locations on the wall and fix the installation board on the wall with M5x30 screws . Ensure that there must be at least 4 fixed points in the wall. Ensure installation board to horizontal position.
- Drill holes as Fig.5 shows. The hole, 80mm in diameter, should slightly slide down outwards..
- Cut PVC tubes at a slight angle in the length shorter than wall thickness and inset it into the hole.( Fig.5 )
- Mount the wall cap.

left side right side

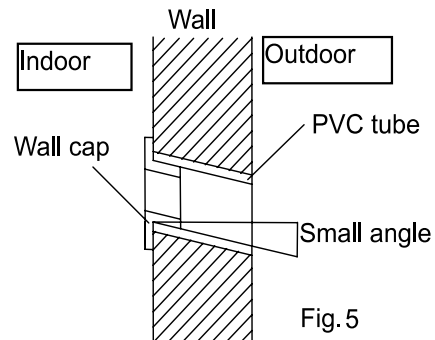
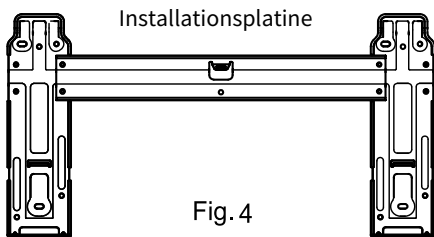

left side right side

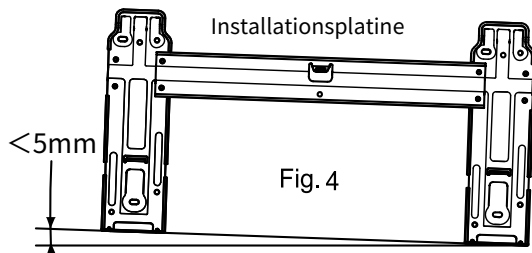

horizontal direction

left side right side

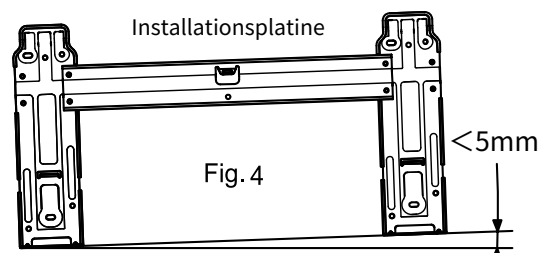

horizontal direction

# Attachment: installation instructions for decorative cover plate

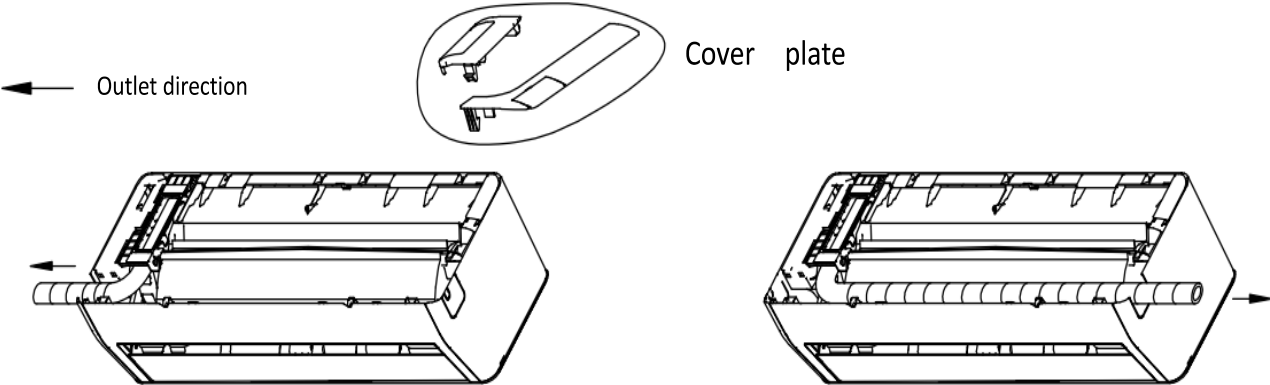

SCHRITT 1: PVC-Schutzband um Abflussrohr, Kupferrohr und Kabel wickeln. Passen Sie das Kupferrohr auf eine geeignete Form an.

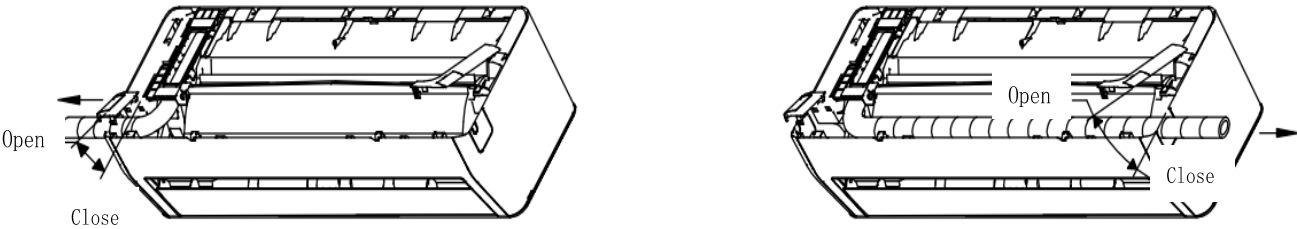

STEP 2: Install the cover plate



STEP 3: Finish

## 〔Indoor Unit Installation〕

The tube may be connected in several directions as below shown Figures.

1. Connecting right back tube (similar to right lower tube) (Optional, Refer to Fig.6)

- Pull out the tubing from bottom of the chassis; and connect the drainpipe. Strap the joint of tubing reliably.
- Lead the connecting wire to the indoor unit (Do not connect to the power).
- Strap together the tubes, discharge pipe and connecting wire with adhesive tape. The discharge pipe is put at the below.
- Remove the board which is on the chassis.
- Check if the connections are reliable.
- Mount the indoor unit on the two hooks at the upper part of installation board. (refer to Fig.8)

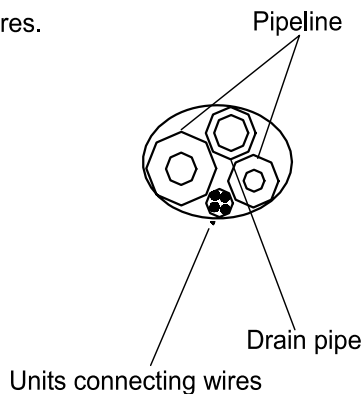

Fig.6

2. Connecting left back tube (similar to left lower tube). (Optional, Refer to Fig9)

- Move the discharge tube to the left side, and discharge cap to the right side.
- Fix the tubes in the slot of the indoor unit with the fix clamp.
- The following mounting steps are the same as those in “1. Connecting right back tube.”

Notes: Left chart is available for the position of drain hose, refer to Fig.7.

Right chart is available for the position of drain hose, refer to Fig.9.

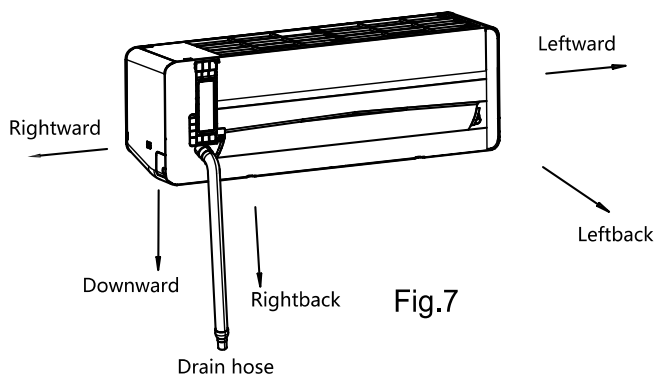

Fig.7

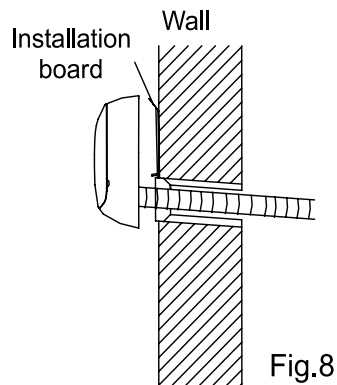

Fig.8

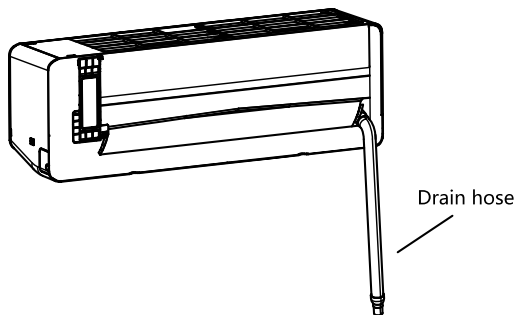
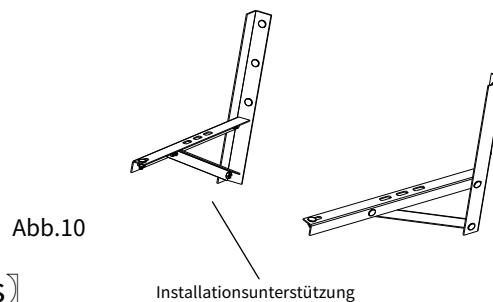

Fig.9

## 〔Installation des Außengeräts〕

- Wenn Installationshalterungen für die Installation des Außengeräts benötigt werden, kann der Benutzer die Halterungen von unserer Firma oder unseren Vertretern kaufen (Abb.10) .
- Montieren Sie den Montagerahmen und die Stützen mit den beigefügten 6 Schrauben, Unterlegscheiben, Federscheiben und Muttern.
- Bohren Sie je nach Fußgröße der Klimaanlage 6 oder mehr Löcher in die Wand. Bestimmen Sie die Positionen für die Montage der linken und rechten Stützen. Stellen Sie sicher, dass sich die linke und die rechte Stütze auf derselben Höhe befinden.
- Einbaurahmen mit Spreizbolzen an der Wand befestigen. Befestigen
- Sie das Außengerät mit 4 Schrauben an den Montagewinkeln.
- Beschläge müssen fest verschraubt sein; Die Verbindung muss fest und zuverlässig sein.
- Bei der Installation des Außengeräts sollte das Gehäuse mit Seilen aufgehängt werden, um ein Herunterfallen zu verhindern. Bei
- der Installation oder Reparatur sollte verhindert werden, dass Werkzeuge und Komponenten herunterfallen. Überprüfen Sie
- regelmäßig die Zuverlässigkeit des Einbaurahmens.



## 〔Schlauchanschluss〕

- Nehmen Sie die Ventilabdeckung der Außeneinheit ab.
- Richten Sie die Bördelmutter auf die Gewindemitte aus und schrauben Sie die Mutter von Hand fest.
- Schrauben Sie die Bördelmutter mit dem Drehmomentschlüssel fest, bis der Drehmomentschlüssel ein „Klick“-Geräusch erzeugt. Es wird empfohlen, zum
- Anschließen des Schlauchs einen Drehmomentschlüssel zu verwenden. Wenn ein anderer flexibler oder starrer Schraubenschlüssel verwendet wird, kann dies die Hornmündung durch unsachgemäße Kraftanwendung beschädigen.
- Der Biegewinkel des Rohrs sollte nicht zu klein sein, sonst kann das Rohr brechen, daher sollte das Wartungspersonal einen Rohrbieger verwenden, um das Rohr zu biegen.
- Lassen Sie niemals Wasser, Staub oder Sand in das Rohr gelangen.

**Tabelle 2**

Schlauchgröße (mm/Zoll)	Drehmoment (Nm)
φ6 (1/4")	15~20
φ9.52(3/8")	35~40
φ12(1/2")	50~55
φ15.88(5/8")	60~75
φ19.05(3/4")	80~95

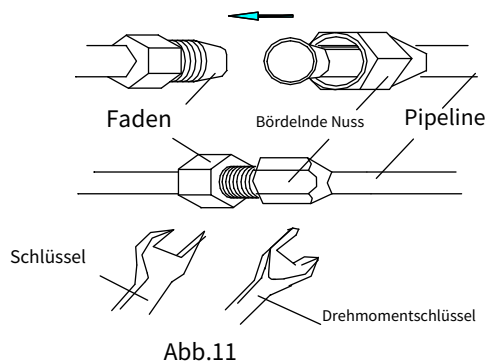

**Abb.11**

## 〔Anschluss von Drähten〕

### 1. Innengerät

- Öffnen Sie das Einlassgitter so weit wie möglich nach oben.
- Entfernen Sie die elektrische Abdeckung vom Gerät.
- Lösen Sie die Schraube am Anschlussdeckel. (Abb.12)
- Demontieren Sie die Drahtdruckplatte.
- Schließen Sie die Leistungsanschlussleitungen und die Signalsteuerleitung separat an die entsprechenden Klemmen an. (In Abb. 14, bitte wählen Sie den gleichen Schaltplan nur mit dem Schaltplan des Geräts.) Lösen Sie die Schraube an der Erdungsplatte; Erdungskabel festdrücken.
- Drücken Sie die Anschlussdrähte des Geräts mit der Anschlusskabel-Druckplatte fest. Schließen Sie den Anschlussdeckel, schrauben Sie ihn fest und schließen Sie das Einlassgitter.



Abb.12

### 2. Außengerät

- Schrauben Sie den Deckel des elektronischen Geräts ab und demontieren Sie ihn (Abb.13). Demontieren Sie die Druckplatte der Drahtbefestigung.
- Schließen Sie die Anschlussdrähte des Geräts separat an die entsprechenden Klemmen an. (Abb.14)
- Drücken Sie die Anschlussdrähte der Einheit mit der oberen Druckplatte fest.
- Bringen Sie den Deckel des elektronischen Geräts wieder an der ursprünglichen Position an.

Wenn der Benutzer das Stromkabel verlängern oder ersetzen möchte, tun Sie dies bitte entsprechend die Tabelle (Tabelle3).

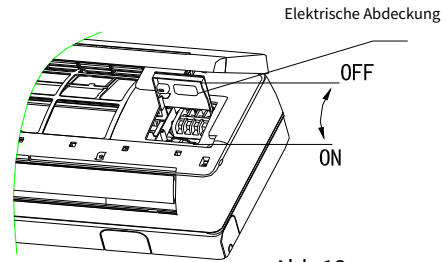

Abb.13

### Tisch 3

		Leistung Drähte	verbinden	Signal Kabel	Kontrolle	Netzkabel
	max. Länge		10m	10m		5m
5K/7K/9K/12K	Kreuz Bereich	Schnitt	$\geq 1,0\text{mm}^2$	$\geq 1,0\text{mm}^2$		$\geq 1,0\text{ mm}^2$
16K/18K			$\geq 1,5\text{mm}^2$	$\geq 1,5\text{mm}^2$		$\geq 1,5\text{mm}^2$
18K/21K/24K/28K			$\geq 2,5\text{mm}^2$	$\geq 0,75\text{ mm}^2$		$\geq 2,5\text{mm}^2$

① Anschlussplan für 7K,9K,12K,18K,24K.

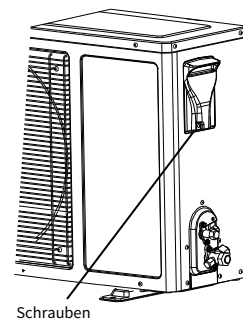

Abb.14

---

## Notes:

- Earthing screw must use special screw(stainless machining screws or copper screws M4)
- Ensure that all wires are securely connected, will not loose or separate.
- Ensure that wire connections are carried out according to the wiring diagram of the air conditioner.
- The above figures are only schematic, and they may be slightly different from the actual appliances you select.

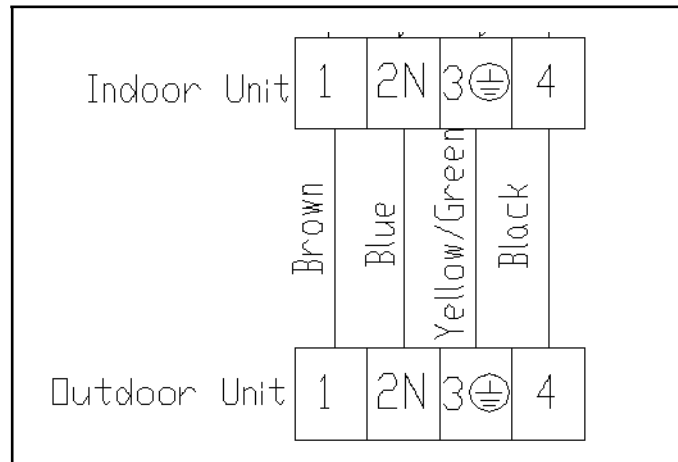
## Tube Strapping

- Strapping with PVC Protective tape must be careful, do not damage the pipeline and drain pipe.
- Strapping should start from the lower part of the outdoor unit to the indoor unit.
- Fix the PVC tape with adhesive tape to prevent loosing.
- Drainpipe should slightly slide down outwards to ensure drainage well.
- When the indoor unit is lower than the outdoor unit, bend the tube to proper extent to prevent water draining into house.
- Fix the tube bundle with tube clamps on the wall.
- Allow enough space between discharge pipe and the ground. Do not put the discharge pipe in water or ditch.
- Seal the external wall holes with sealing gum or putty.

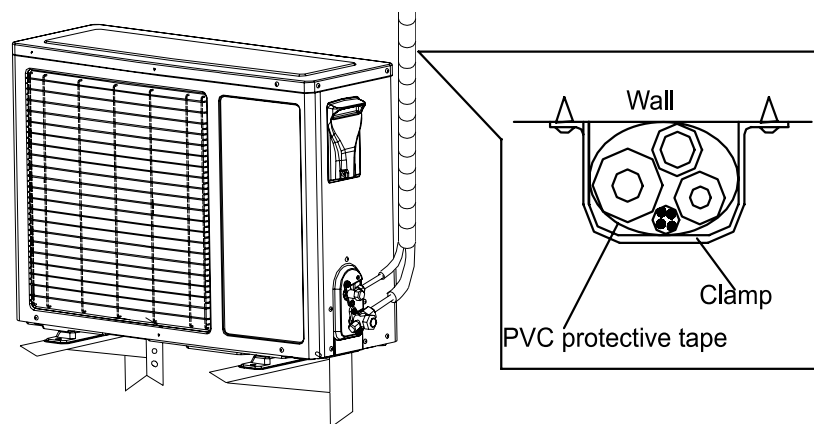
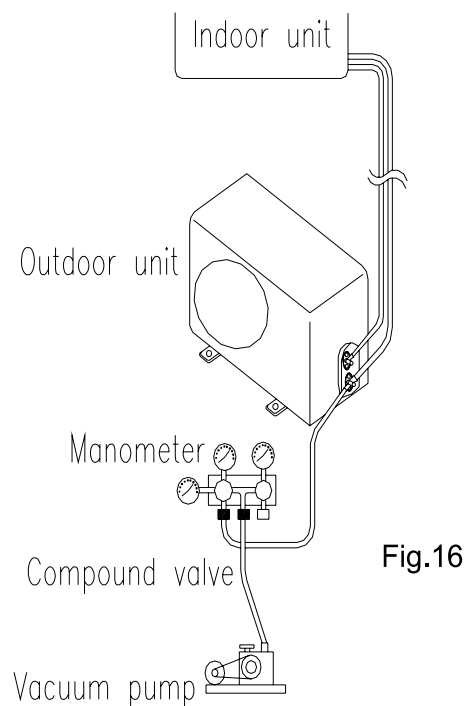

Fig.15

---

## Pumping type

- Make sure that all the tubes of indoor and outdoor unit are connecting well.
- Take off valve bonnet from two-way and three-way valves by spanner; connect vacuum pump and compound valve to the service valve bonnet.
- Open the low-pressure switch of compound valve, and run vacuum pump until units' internal pressure at 10 mmHg.
- After pump vacuum, close the low-pressure switch of compound valve, and then close vacuum pump. Turn anti-clockwise 90° Spool of narrow pipe service valve by hexagon spanner, tightly with clockwise turning after stopping for 10 seconds.
- Check with soap water or leak detector whether there is leakage at all connections of indoor and outdoor unit.
- Open wide and narrow pipe service valves by hexagon spanner for running.
- Take off the connection pipeline of wide pipe service valve.
- Screw tightly the entire valve bonnet by torque spanner.
- Check with soap water or leak detector whether there are leakage at all indoor and outdoors' connections.
- Put the valve bonnet and lid back to position.





---

## [ Drainage ]

### 1. No need drainage treatment

In regions where become cold in the winter, don't install the drain elbow joint to prevent drain water from freezing and causing the fan to be damaged. This drainage treatment is not necessary for cooling-only type air conditioner.

### 2. When need drainage treatment

- Please use drain elbow joint (in accessory bag). Outdoor unit should be placed on blocks.

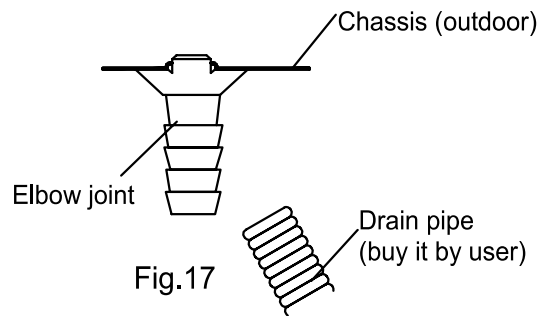

Installation for the cover of valve:

For the whole unit that individual cover of valve is available (refer to packing list), the installing method is as follow:

After connecting the connection pipes between indoor and outdoor units followed by the installing method mentioned above, take out the cover of valve from the accessory bag, and fix it on the side of outdoor unit with three corresponding screws ( inside the accessory bag ).

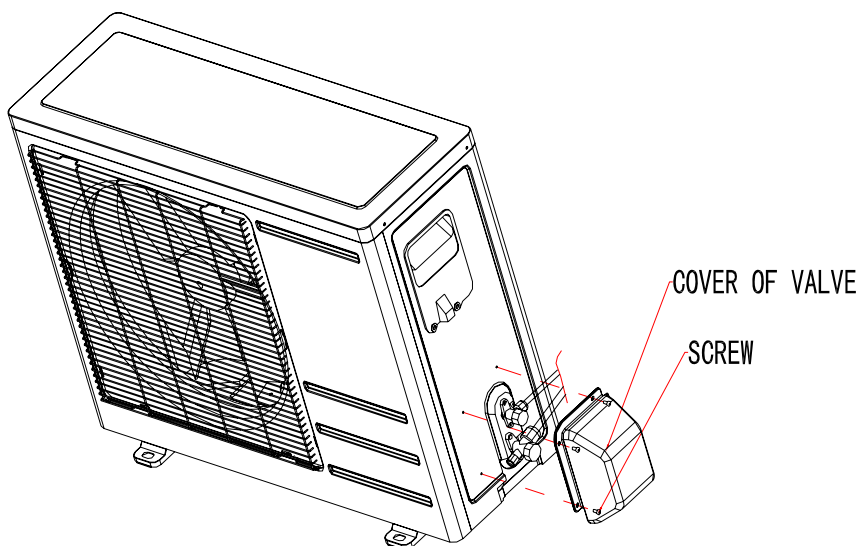

Fig.18

**ARYA**  
W E L L N E S S   A I R

[www.aryaclima.it](http://www.aryaclima.it)

[info@aryaclima.it](mailto:info@aryaclima.it)

